

ASSEMBLY INSTRUCTION

MCLEAN

CLOUD SINGLE STORAGE BED

ITEM CODE 79846

Model 2: DRAWERS AT LEFT SIDE

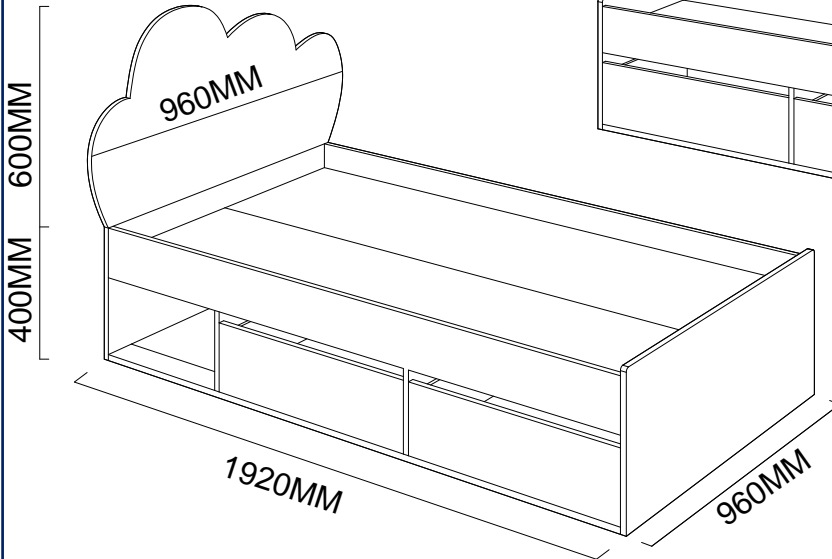
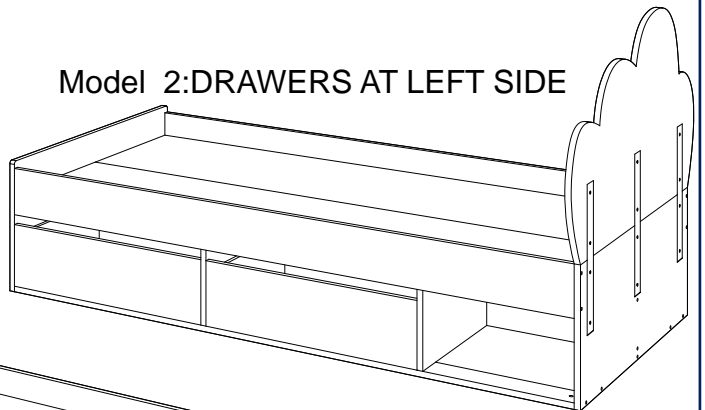

Model 1: DRAWERS AT RIGHT SIDE

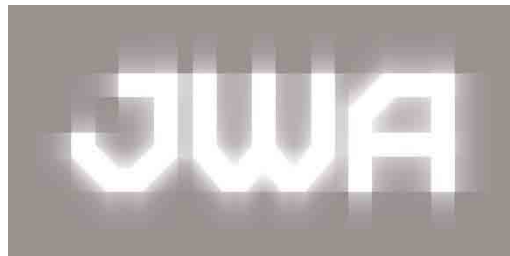

Imported by JWA Furniture Pty Ltd, Qld, Brisbane Australia.
For any assistance with assembly or for missing parts please refer to your receipt

PRE-ASSEMBLY PREPARATION

Before you start:



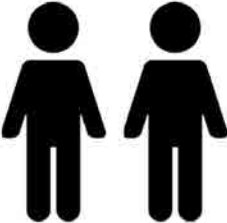
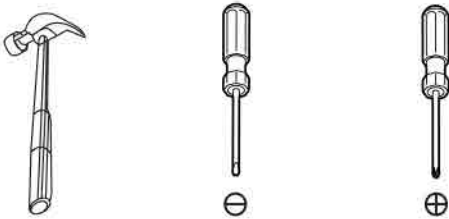



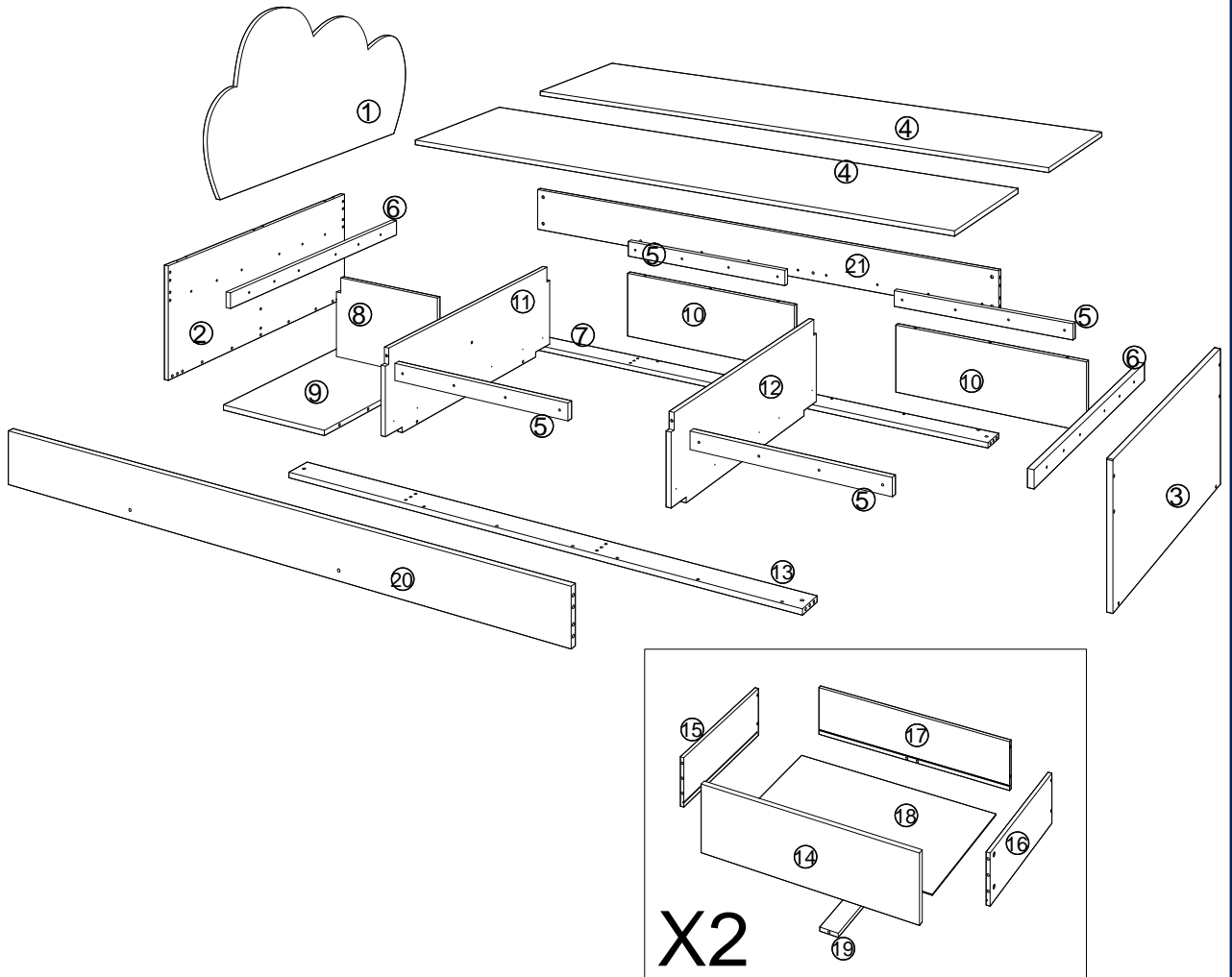



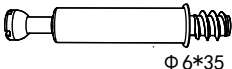
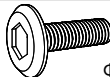

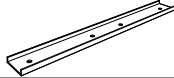

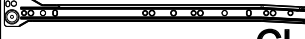
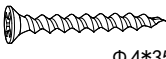
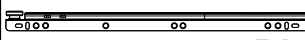

1. Choose a clean, level, spacious assembly area. Avoid hard surfaces that may damage the product
2. Take care when lifting. Product should be assembled as near as possible to the point of use
3. Ensure that you have all required contents for complete assembly
4. Always read the assembly instructions carefully before beginning assembly.
5. Keep all hardware parts and packaging out of reach of small children.
6. Do not over tighten the screws and bolts as this may damage the threads

		
Allow 1 hour	For 2 person	Additional tools required

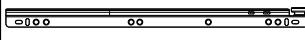
PARTS LIST

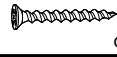

PARTS LIST

NO.	ITEM	QTY	NO.	ITEM	QTY
A	 Φ 6*35	10PCS	K	 Φ 6*18	12PCS
B	 Φ 15*10	10PCS	L		3PCS
C	 Φ 6*30	42PCS	M	 Φ 3*12	24PCS
D		13PCS	N	 CL	2PCS
E	 Φ 4*35	12PCS		 DL	
F		1PC		 CR	
G		16PCS		 DR	
H	 Φ 6*40	16PCS	O	 Φ 4*25	28PCS
I		12PCS	P	 Φ 4*40	18PCS
J		12PCS	Q	 Φ 8*40	4PCS

PARTS LIST

NO.	ITEM	QTY	NO.	ITEM	QTY
①	HEADBOARD	1 PC	⑬	BOTTOM SUPPORT PANEL	1 PC
②	BEDHEAD BOTTOM PANEL	1 PC	⑭	DRAWER FRONT PANEL	2 PCS
③	FOOTBOARD	1 PC	⑮	DRAWER LEFT SIDE PANEL	2 PCS
④	BED BOARD	2 PCS	⑯	DRAWER RIGHT SIDE PANEL	2 PCS
⑤	SUPPORT PANEL	4 PCS	⑰	DRAWER BACK PANEL	2 PCS
⑥	SUPPORT PANEL	2 PCS	⑱	DRAWER BOTTOM PANEL	2 PCS
⑦	BOTTOM SUPPORT PANEL	1 PC	⑲	DRAWER BOTTOM SUPPORT PANEL	2 PCS
⑧	MIDDLE SUPPORT PANEL	1 PC	⑳	RAIL	1 PC
⑨	BOTTOM PANEL	1 PC	㉑	RAIL	1 PC
⑩	SIDE PANEL	2 PCS			
⑪	MIDDLE SUPPORT PANEL	1 PC			
⑫	MIDDLE SUPPORT PANEL	1 PC			

STEP 1:

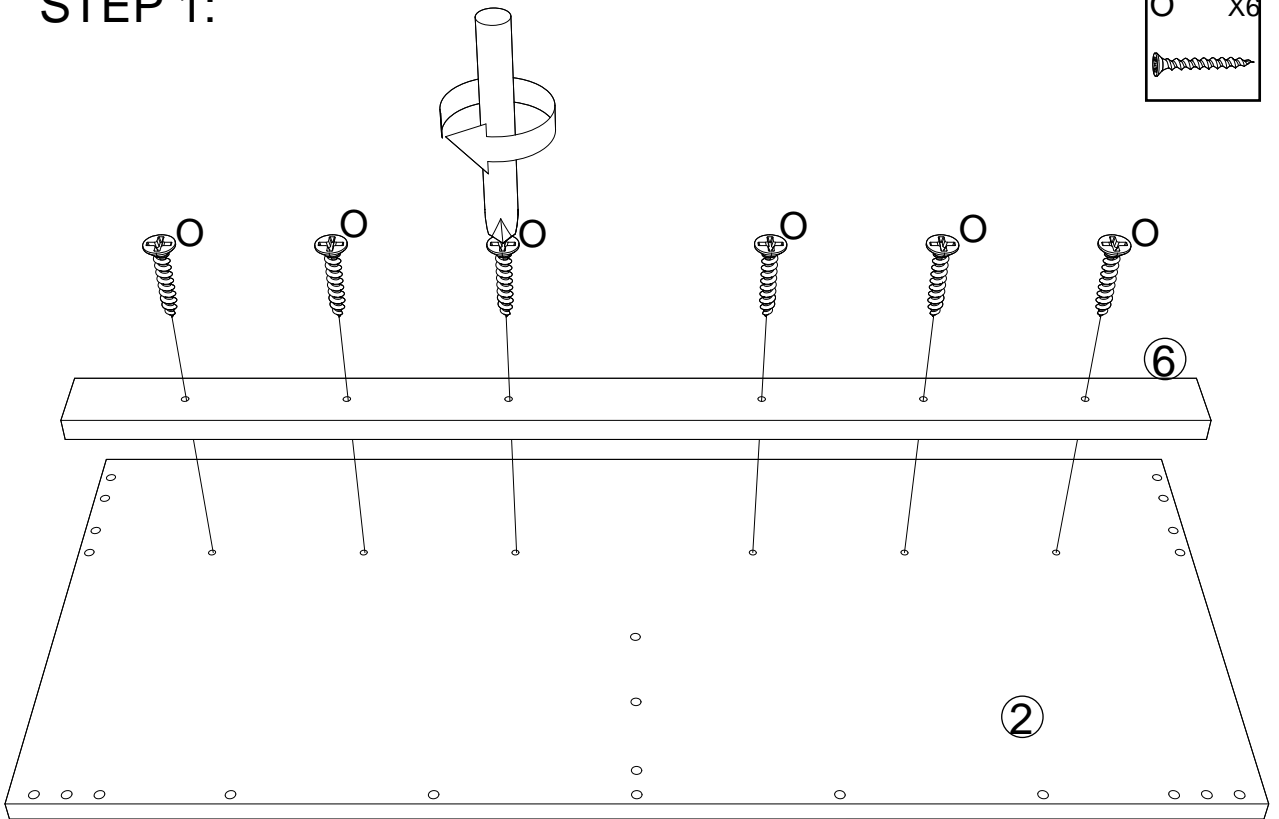
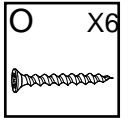

STEP 2:

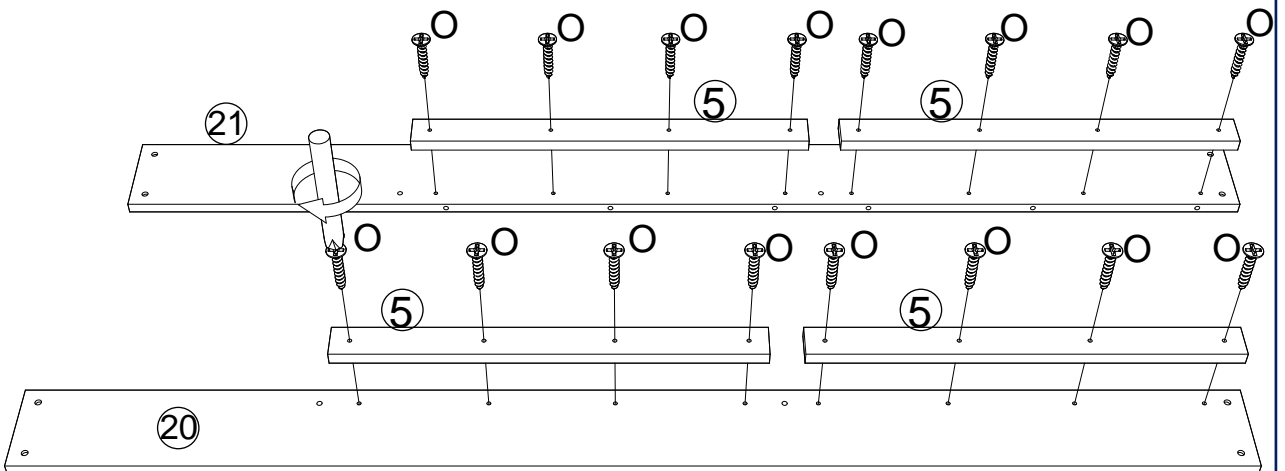
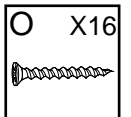

STEP 3:

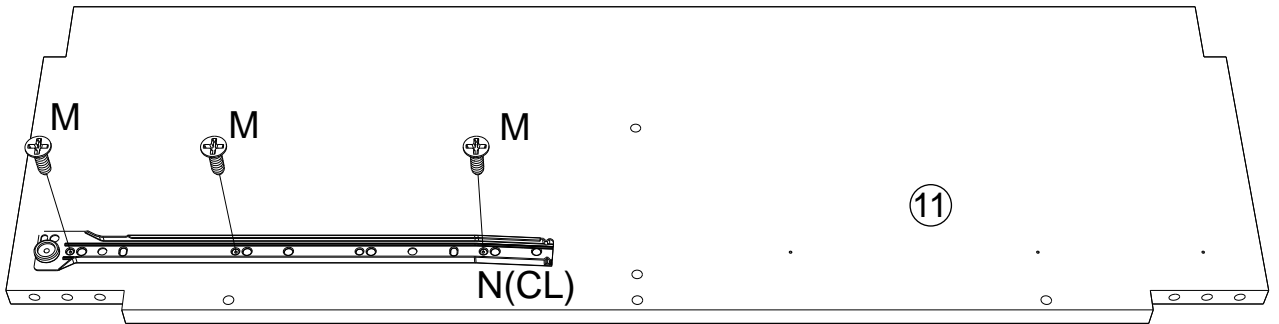
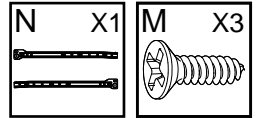

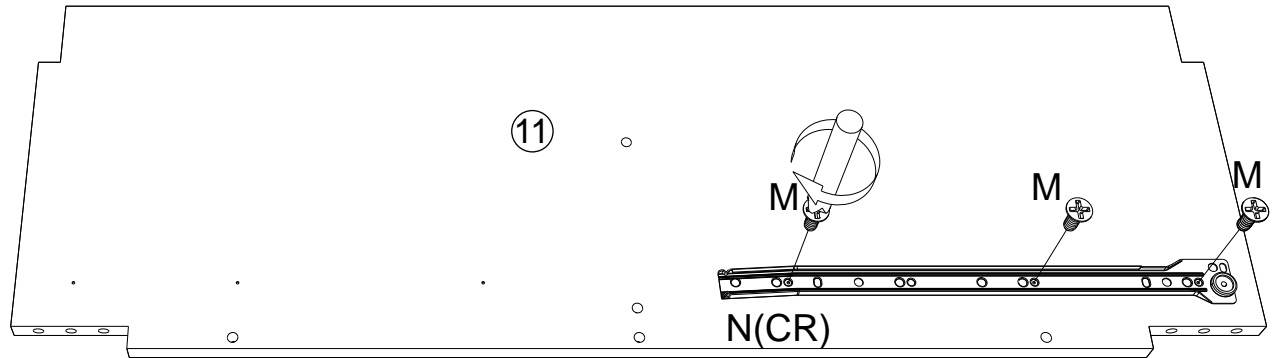

Model 1

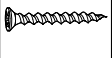
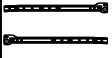

Model 2

STEP 4:

O	X6	N	X1	M	X3
					

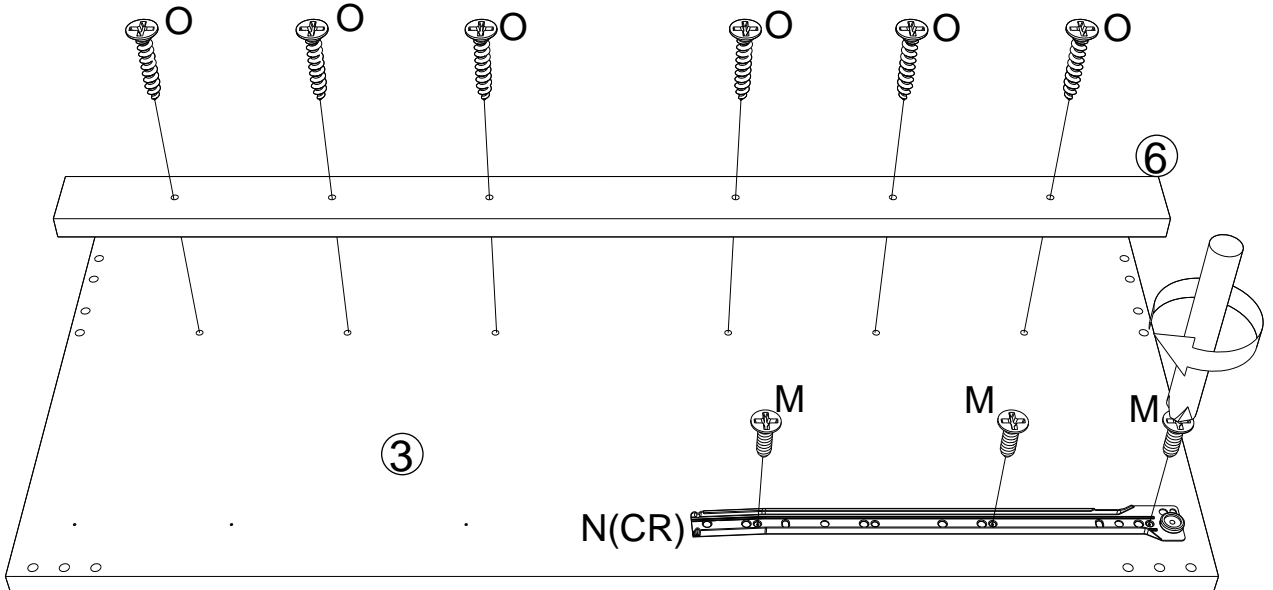

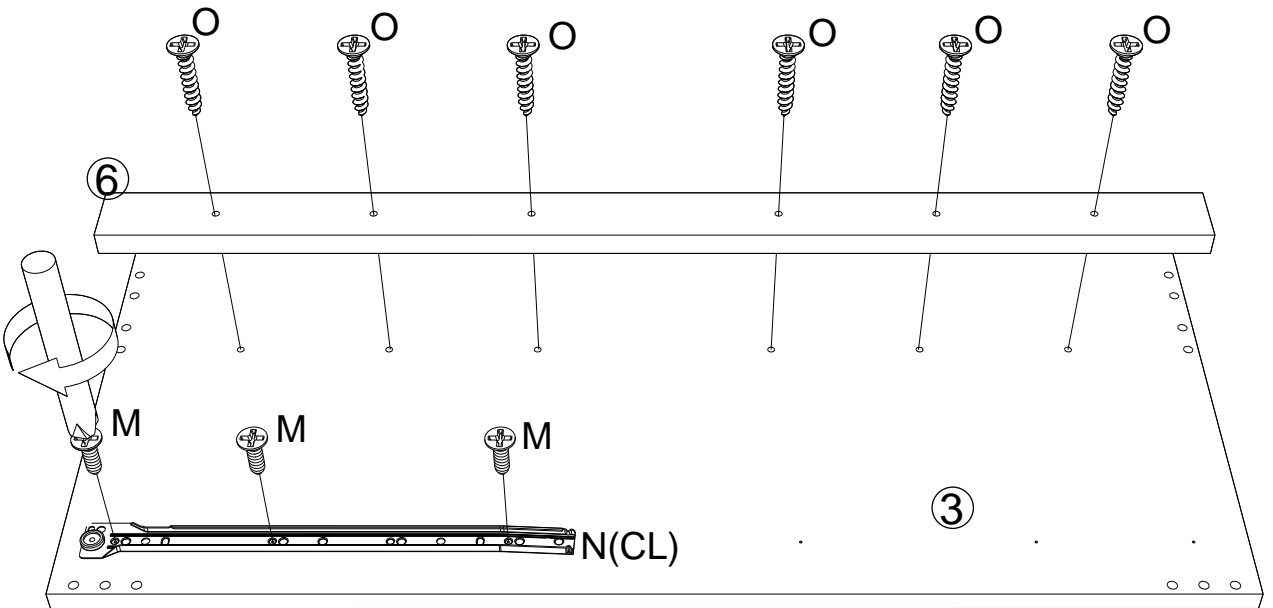

Model 1

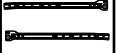

Model 2

STEP 5:

N	X1	M	X6
			

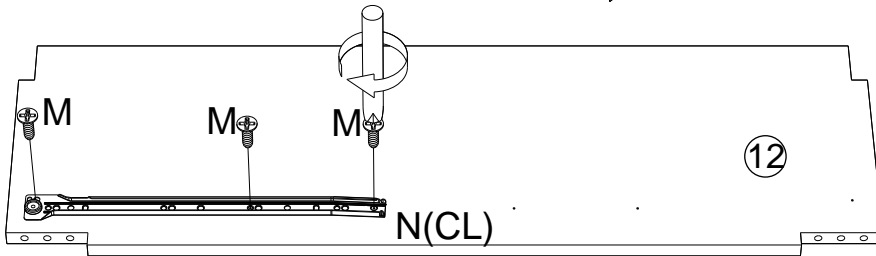
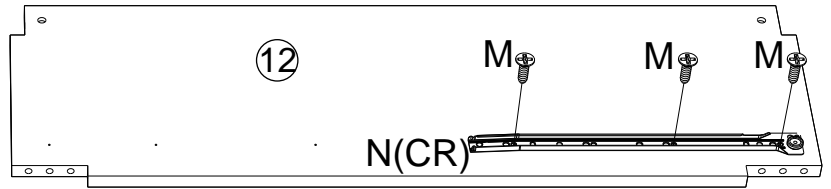

Model 1

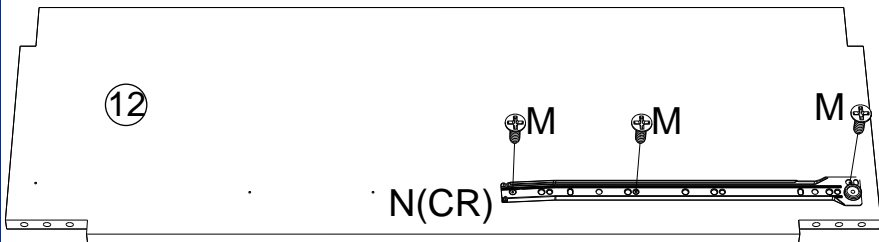
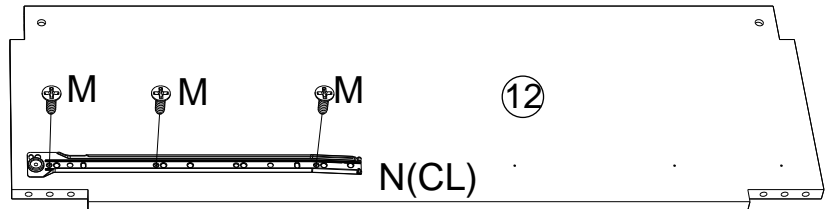

Model 2

STEP 6:

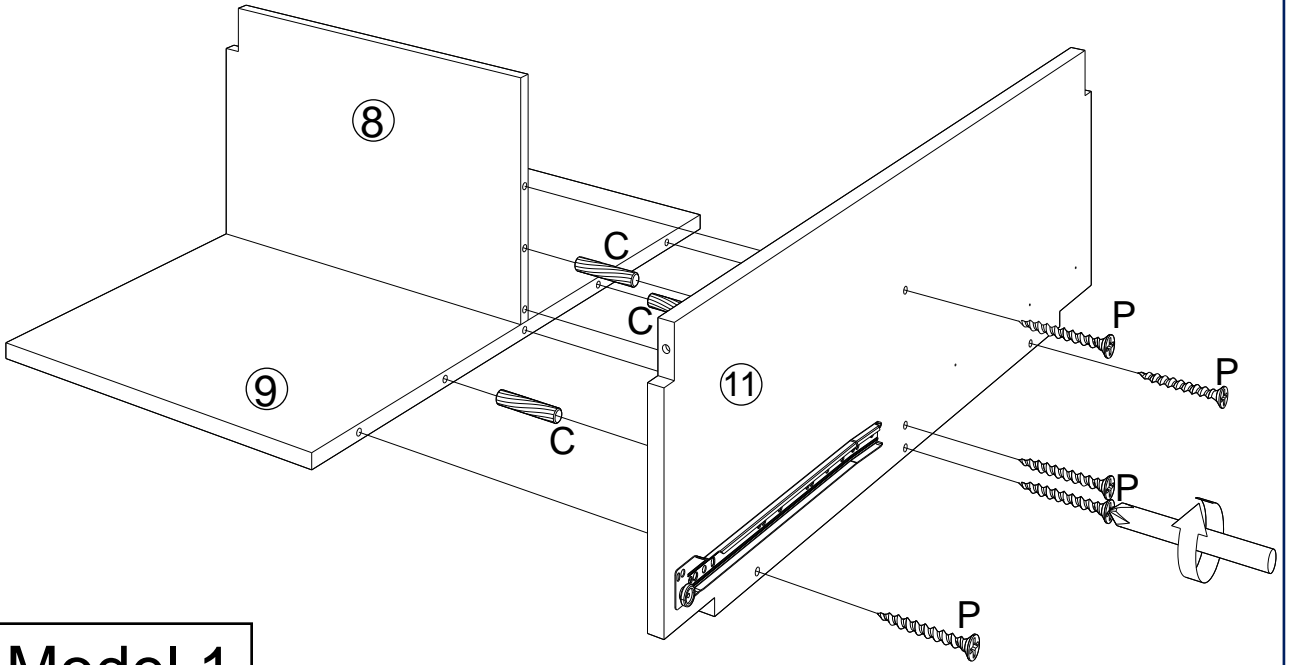
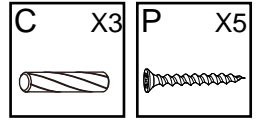

Model 1

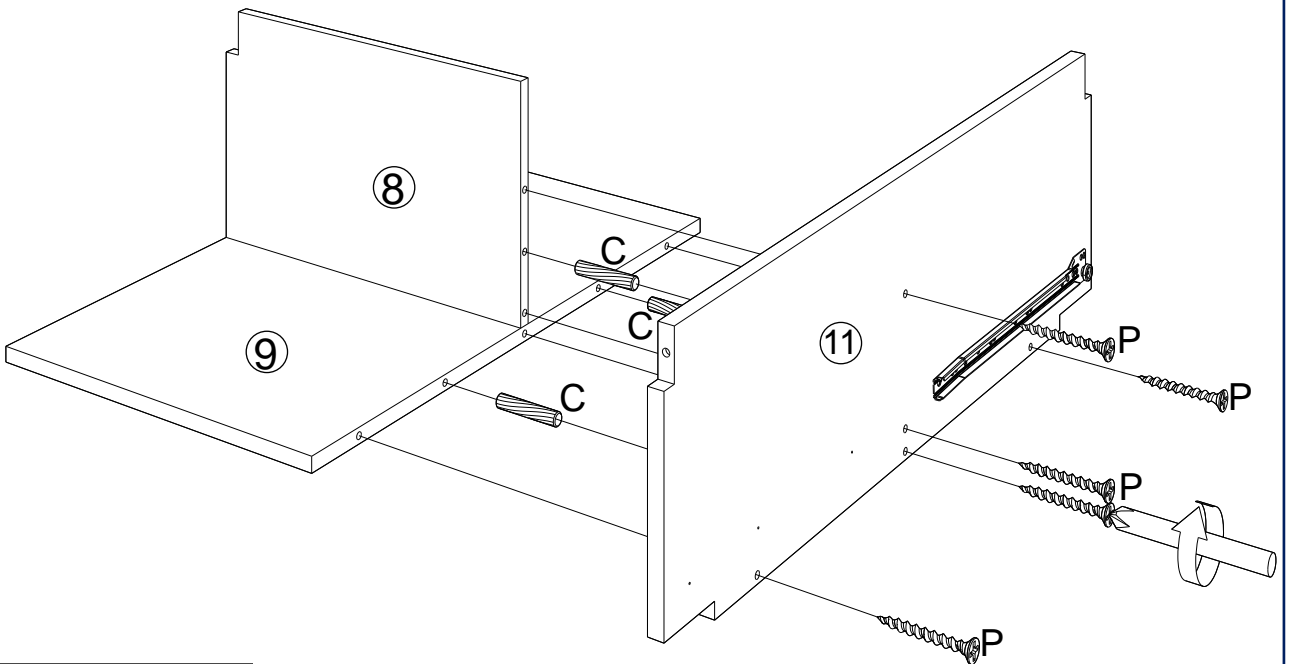

Model 2

STEP 7:

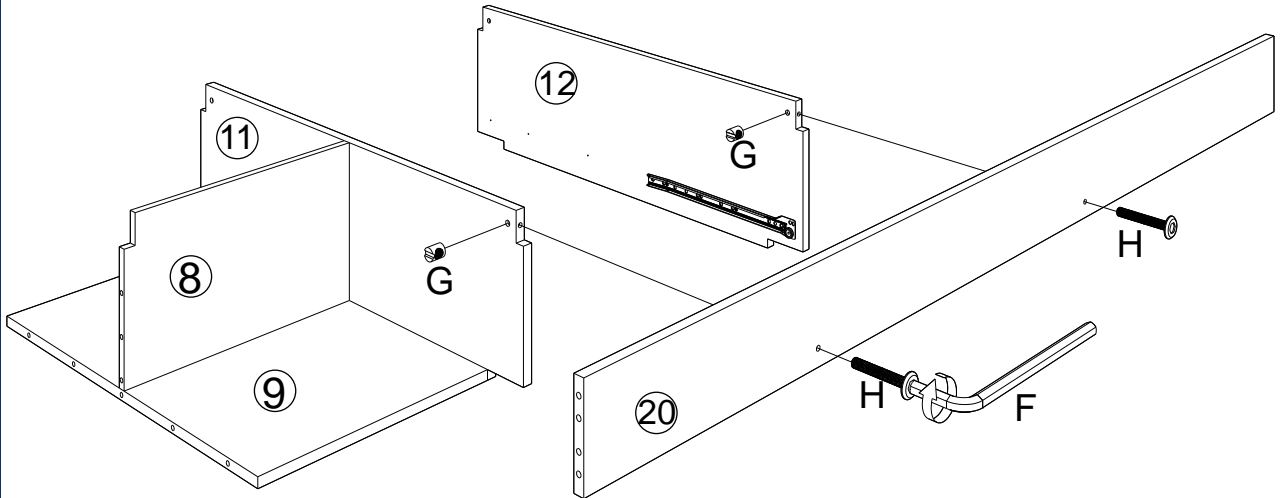

Model 1

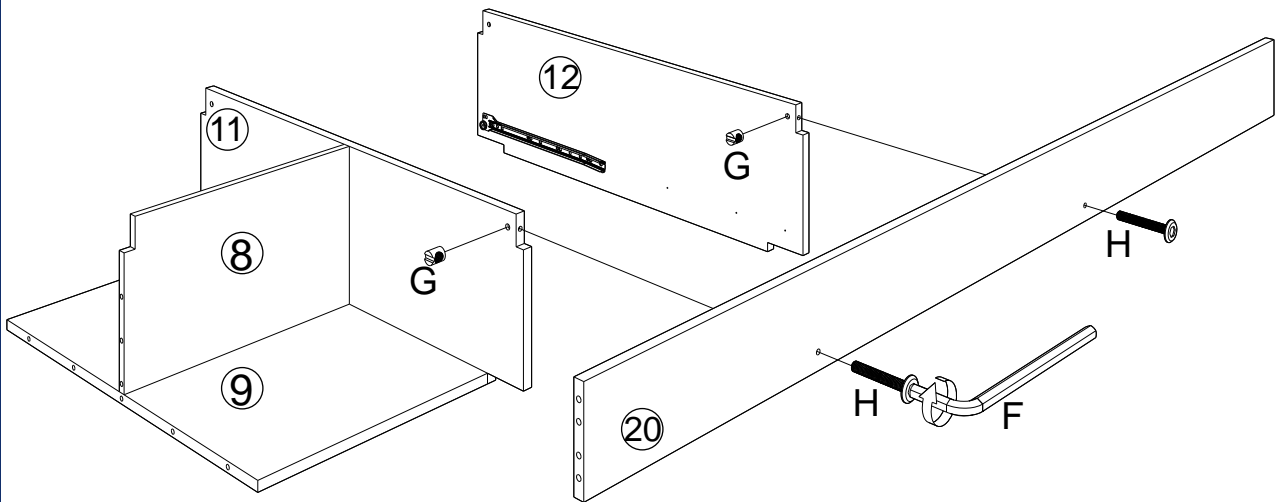

Model 2

STEP 8:

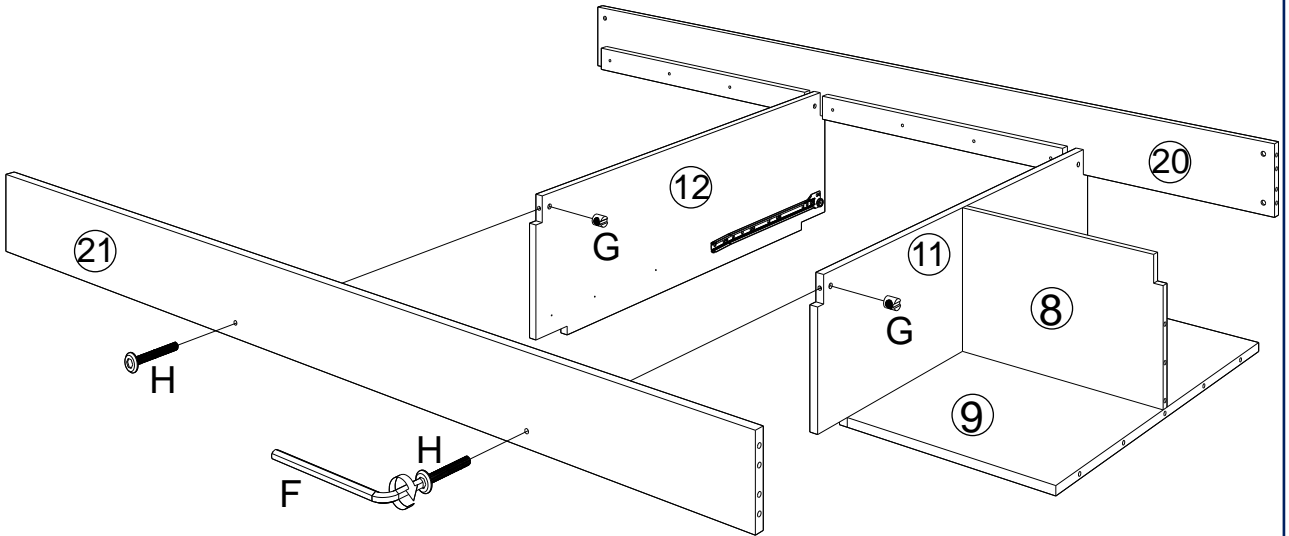
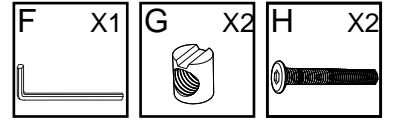

Model 1

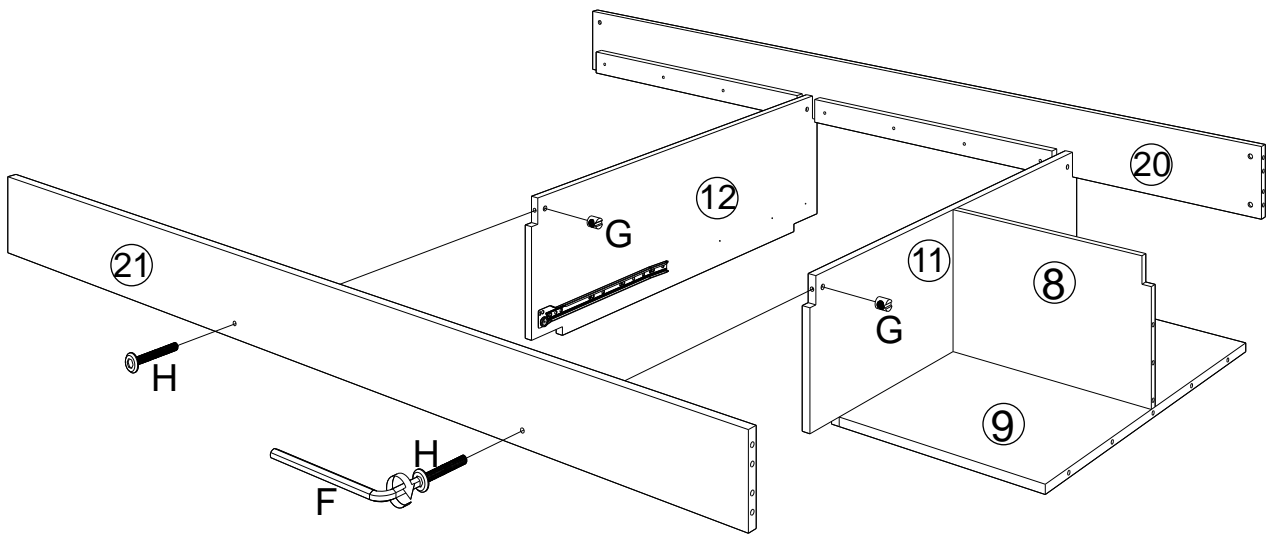

Model 2

STEP 9:

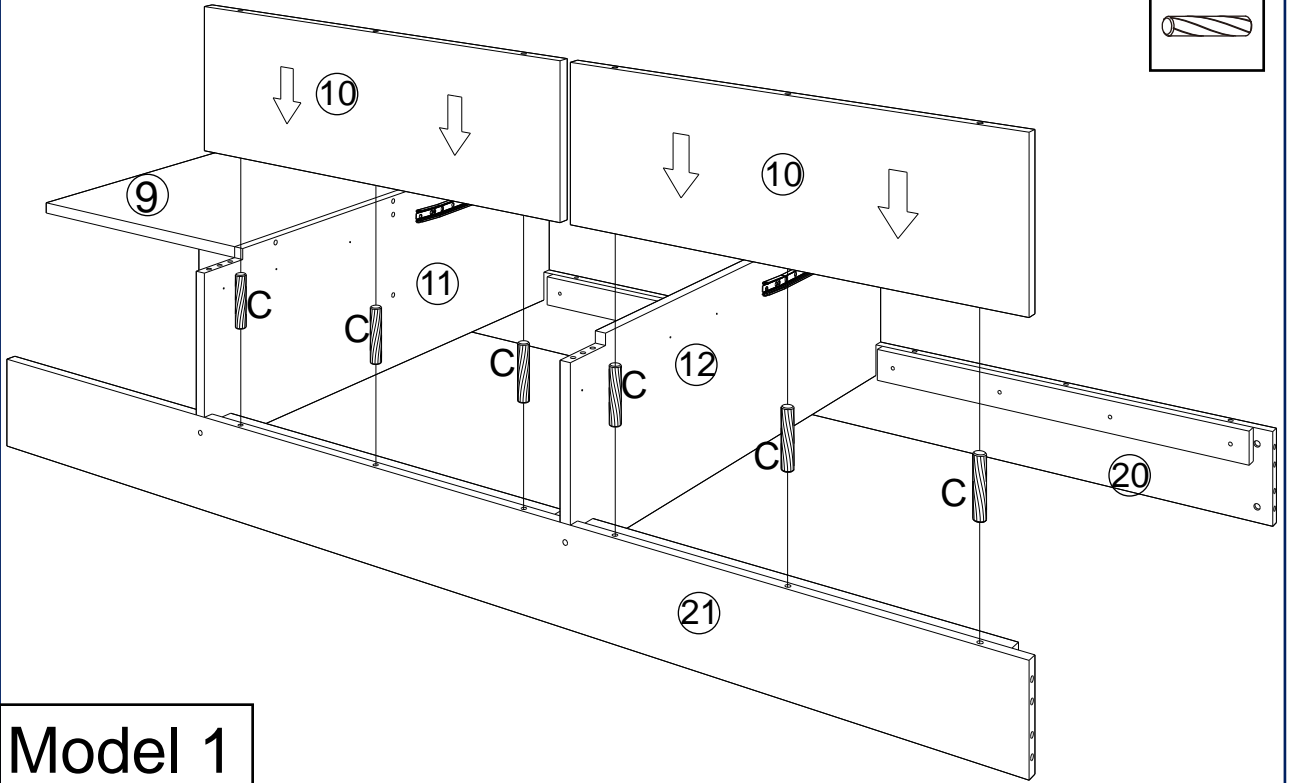
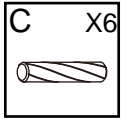

Model 1

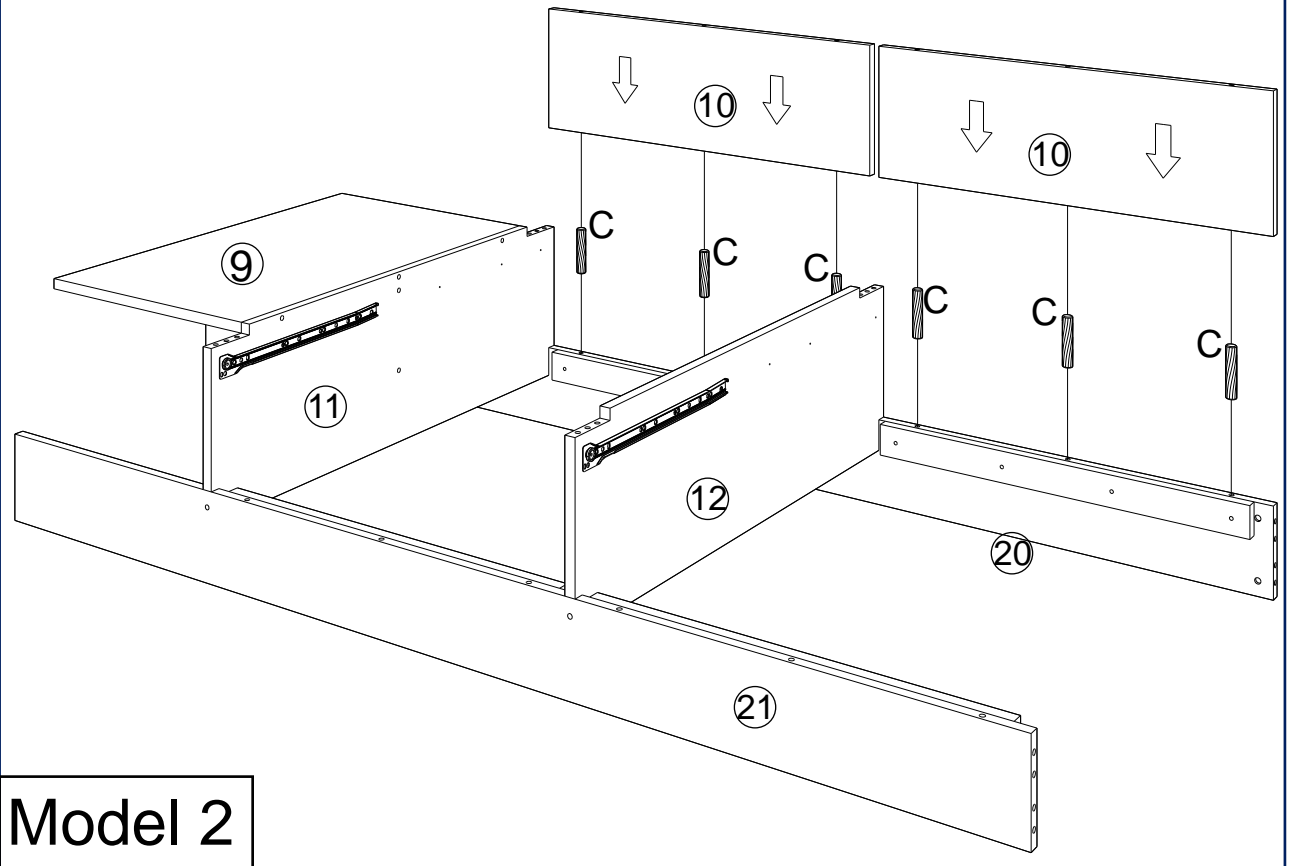

Model 2

STEP 10:

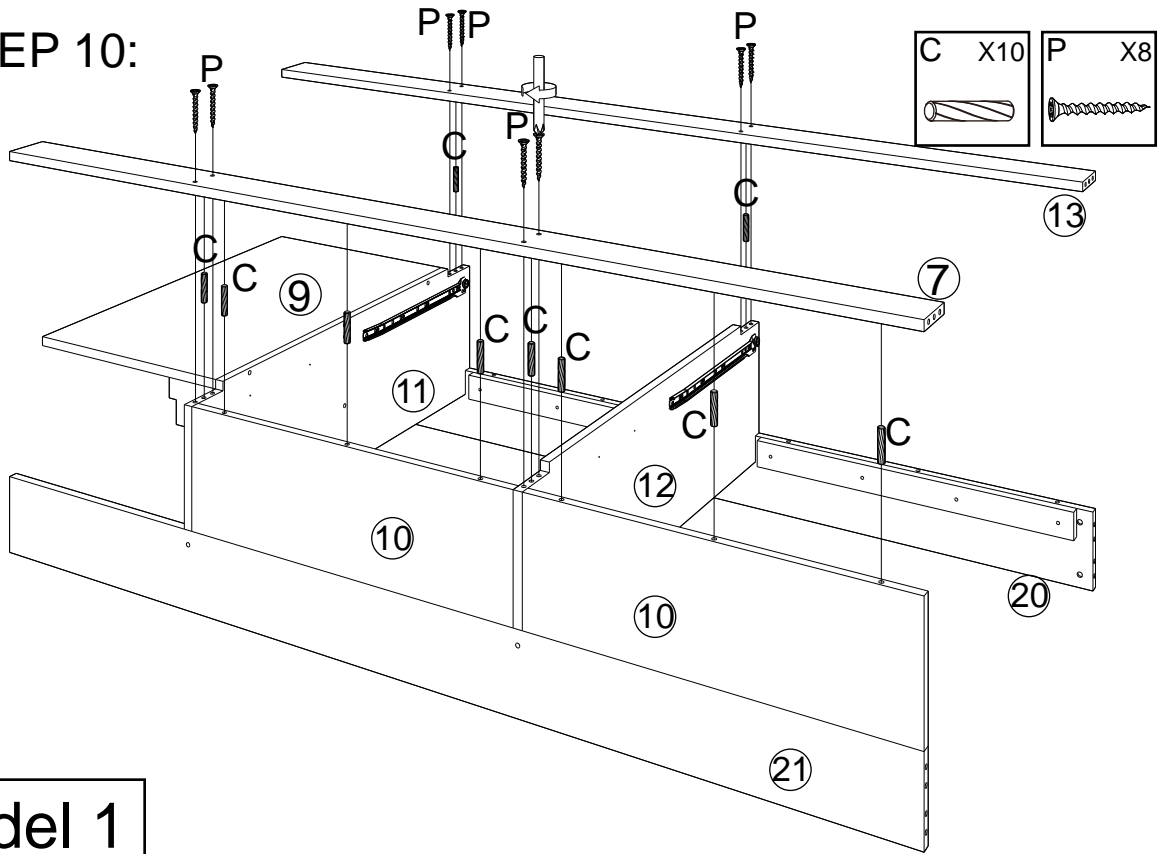

Model 1

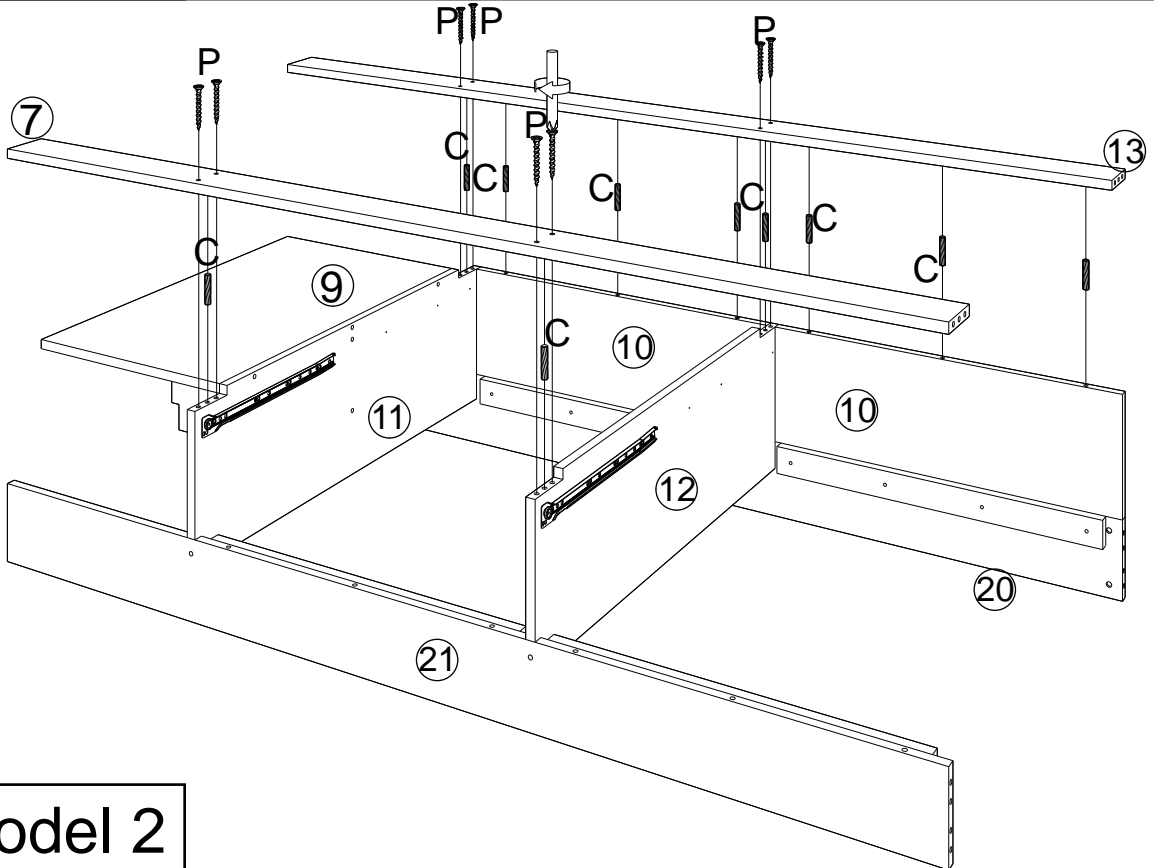

Model 2

STEP 11:

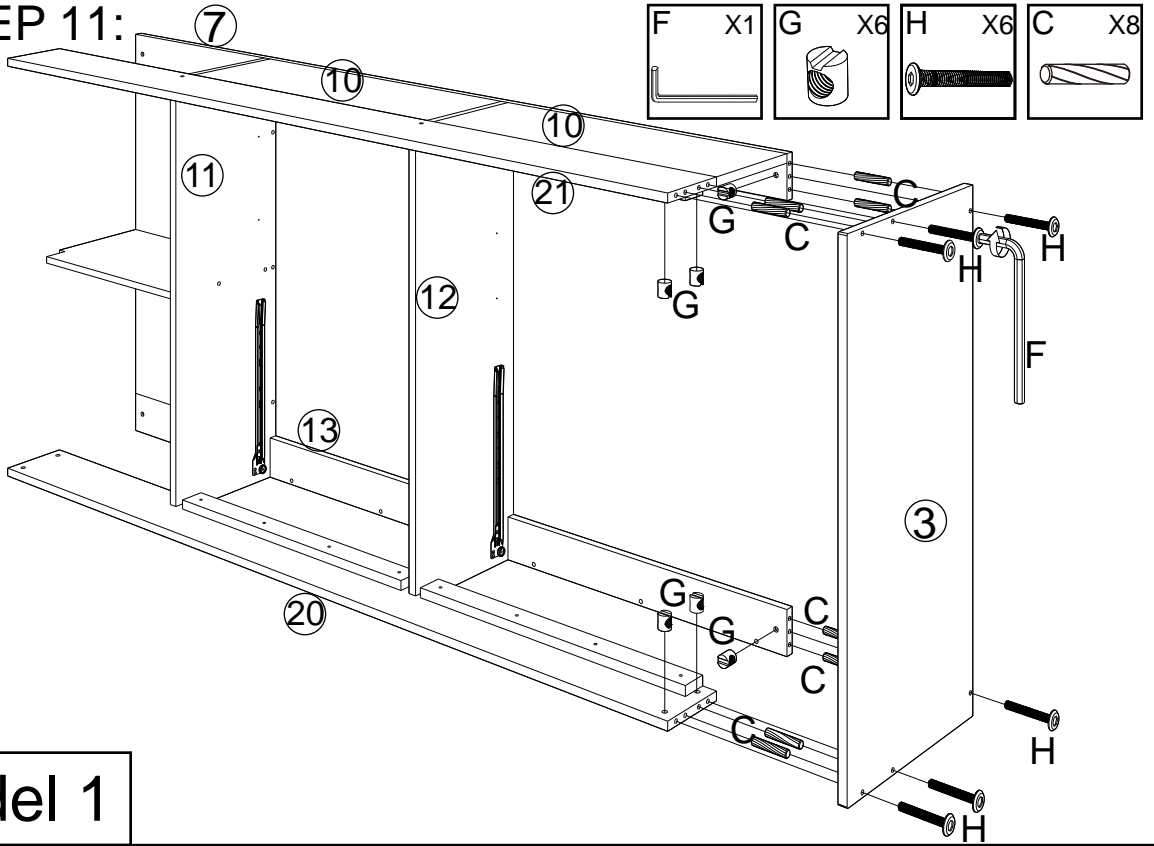

Model 1

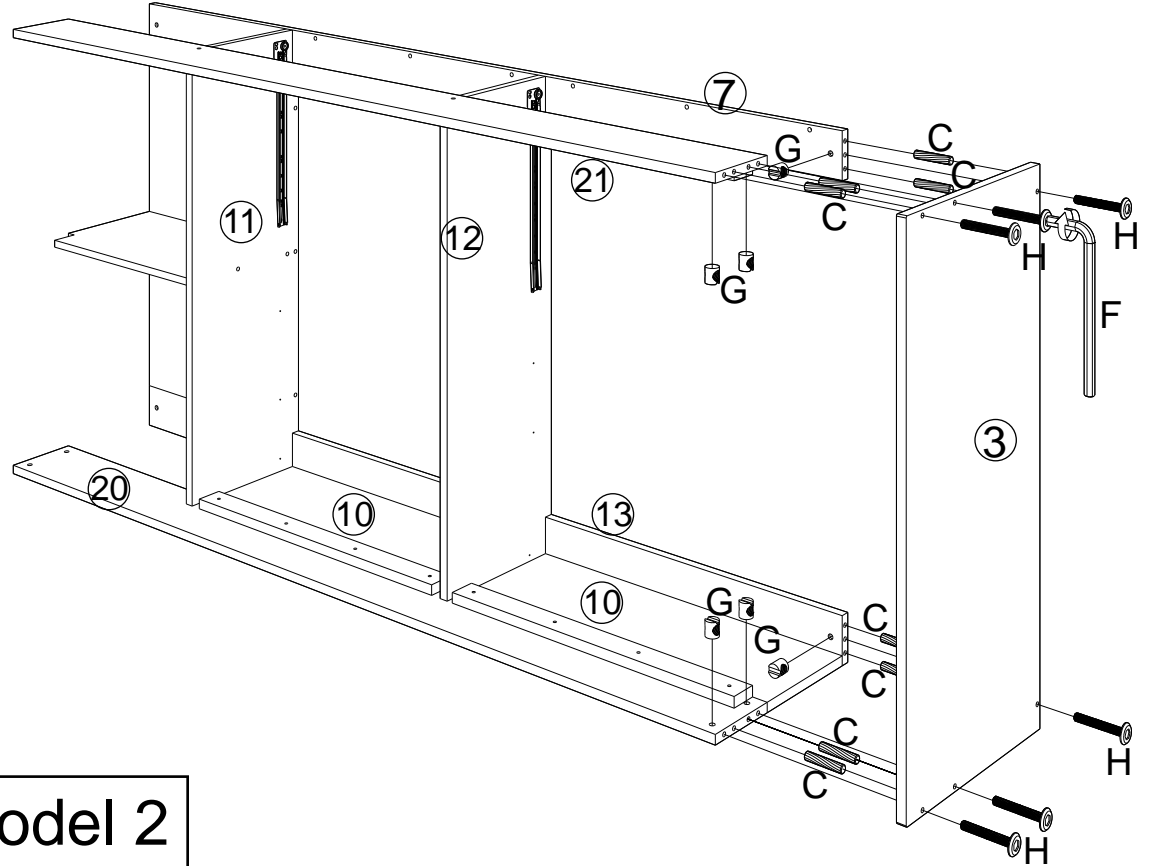

Model 2

STEP 12:

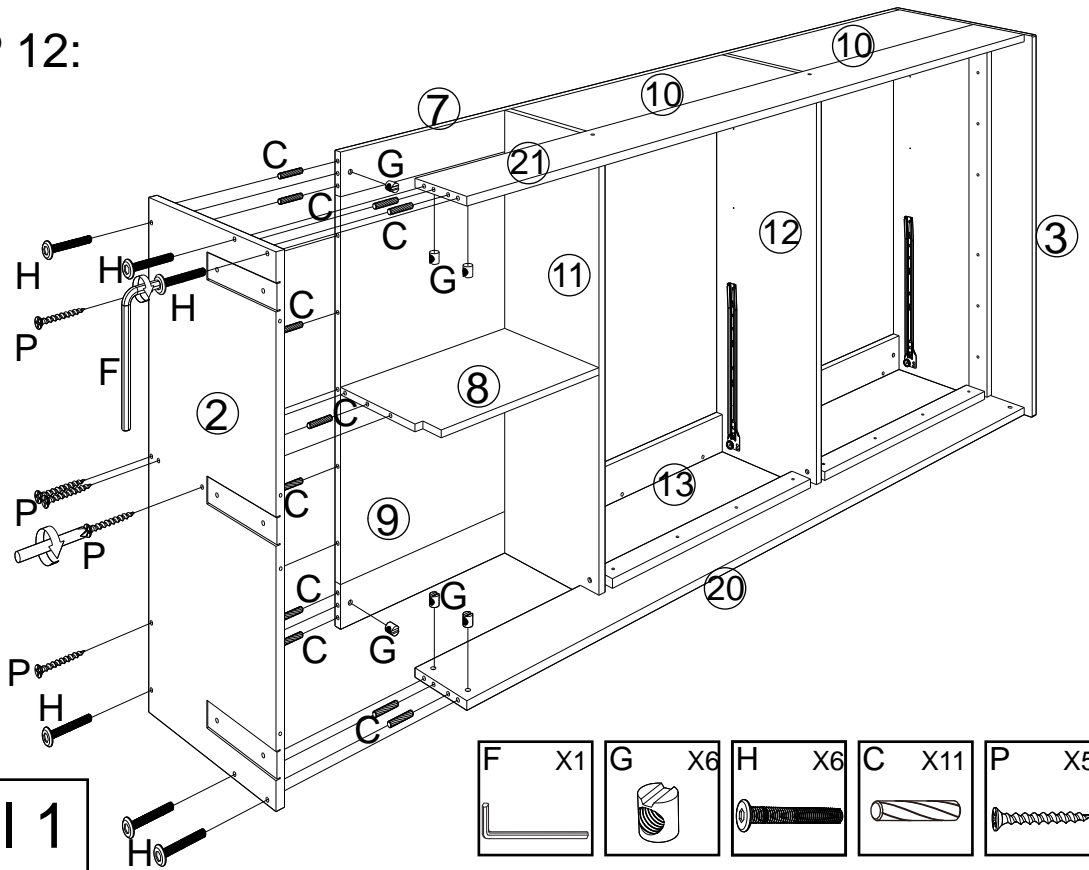

F	X1	G	X6	H	X6	C	X11	P	X5
---	----	---	----	---	----	---	-----	---	----

Model 1

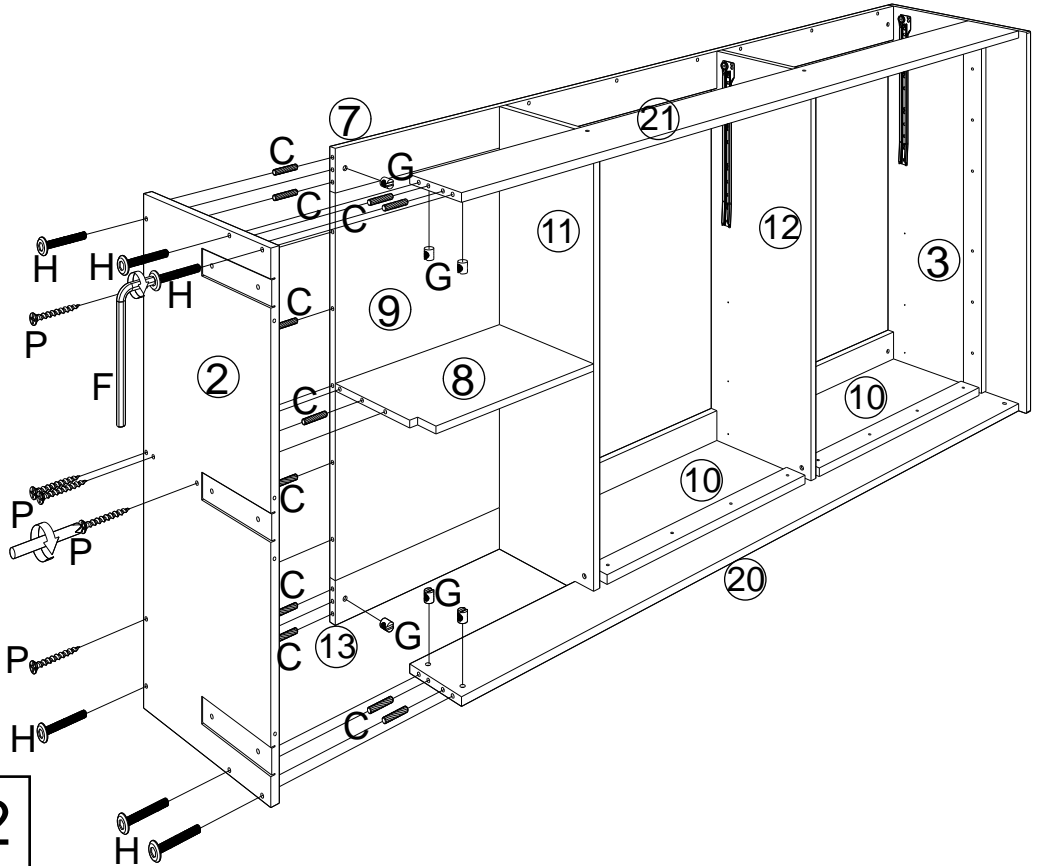

Model 2

STEP 13:

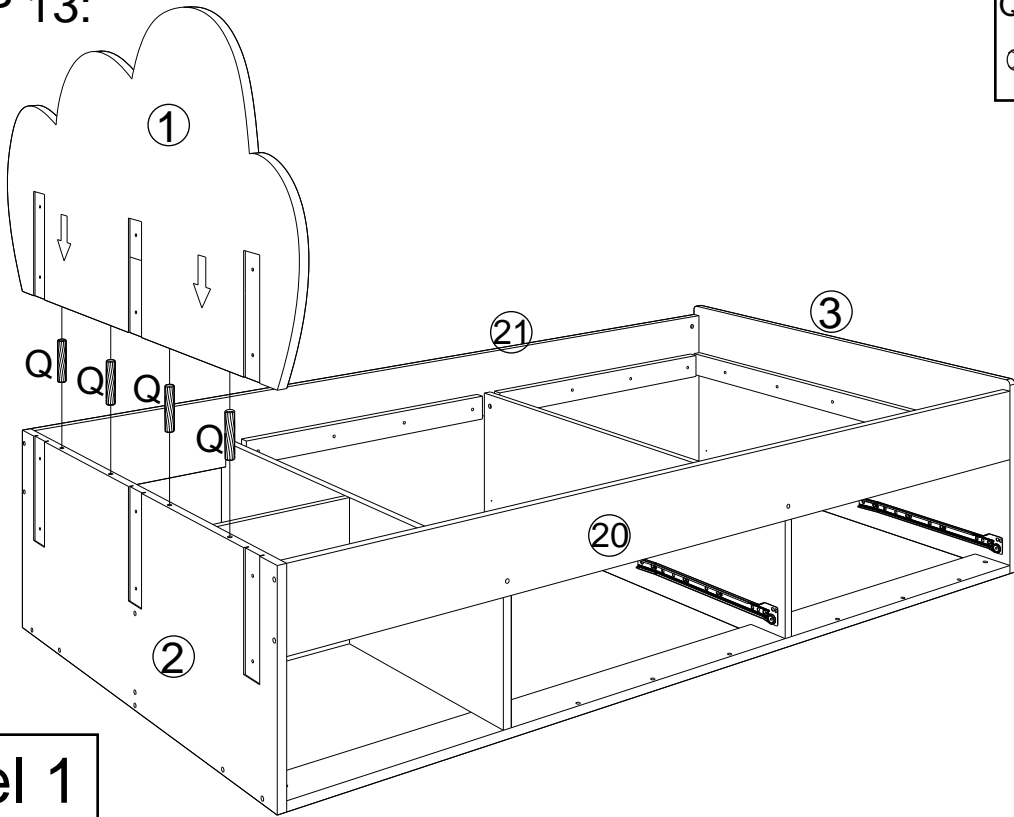
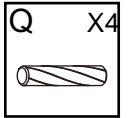

Model 1

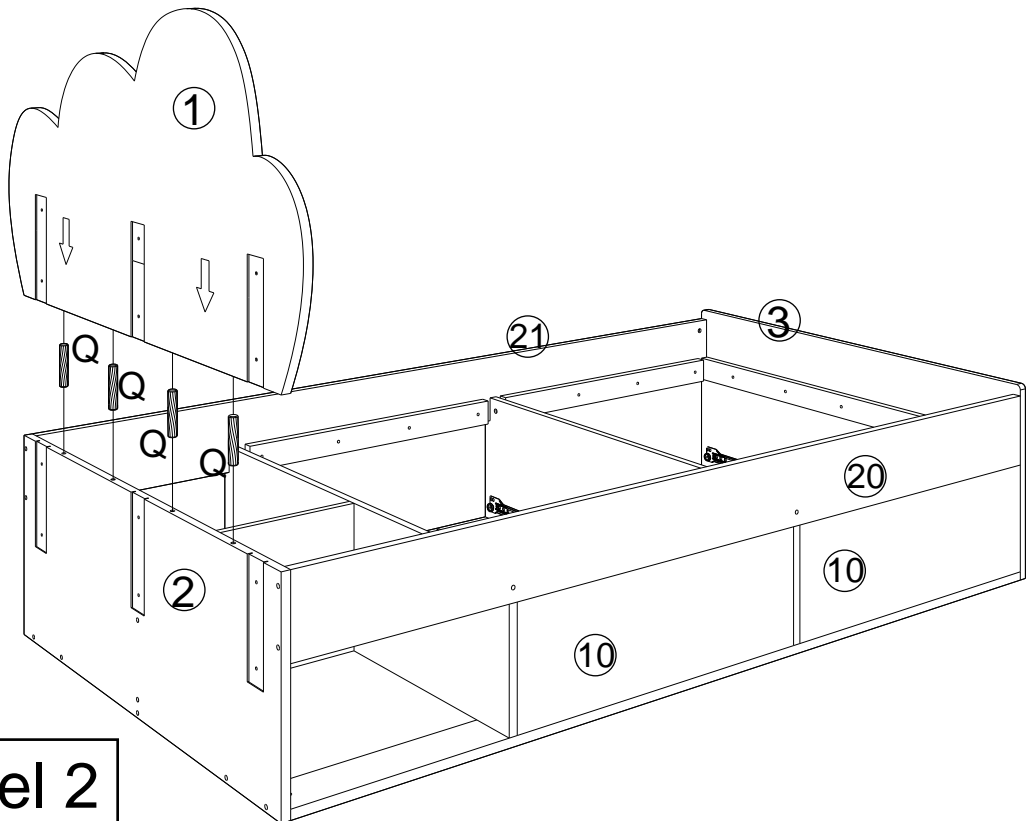

Model 2

STEP 14:

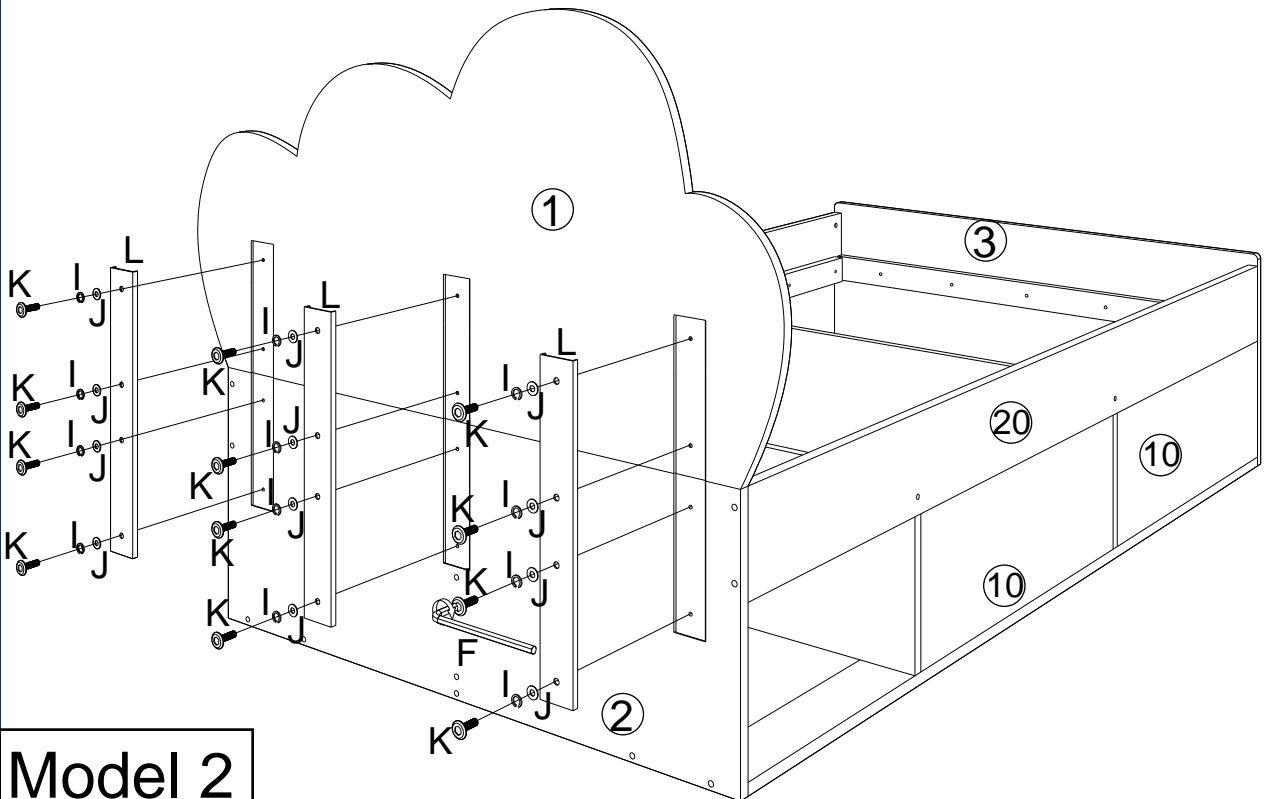
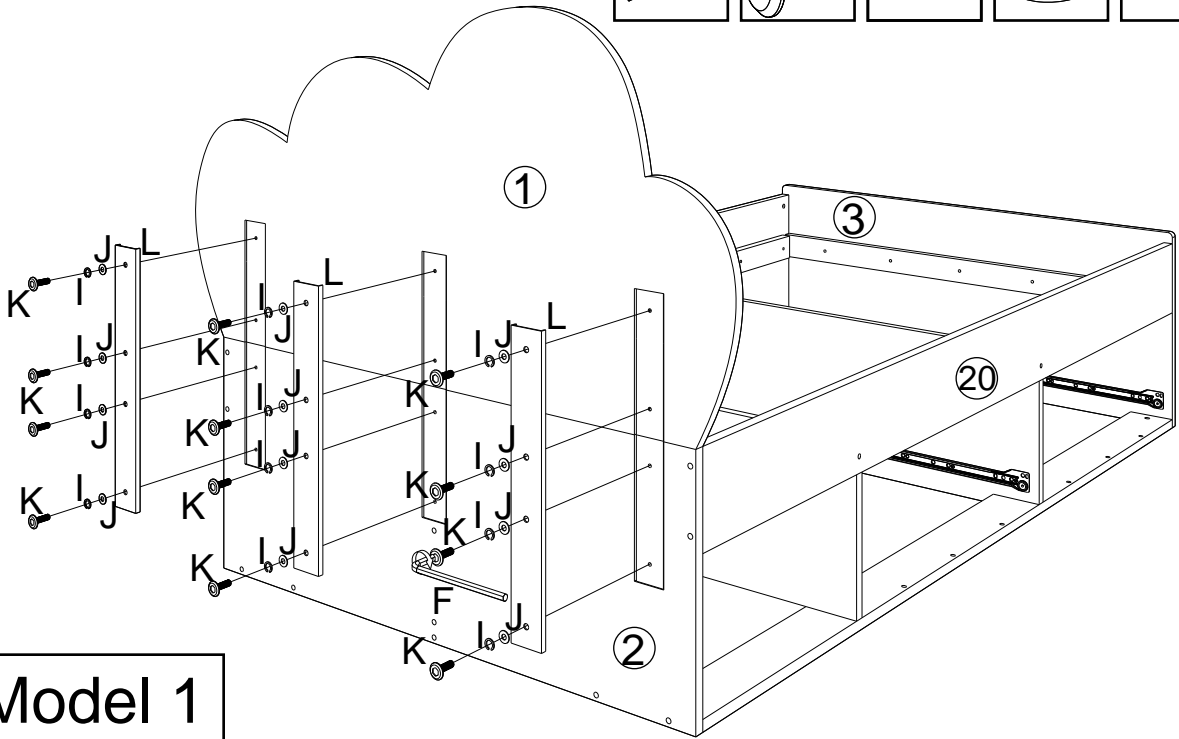
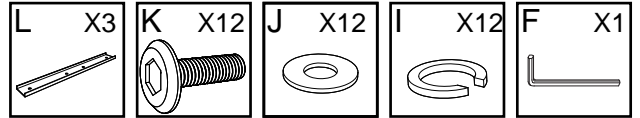

STEP 15:

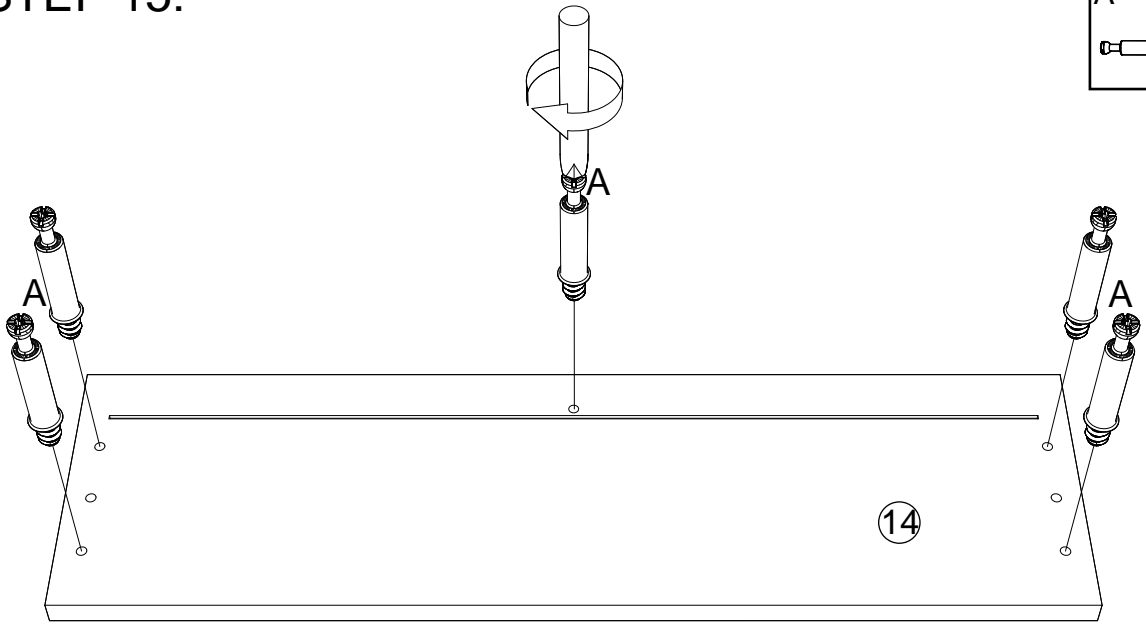
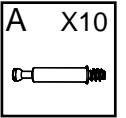

X2

STEP 16:

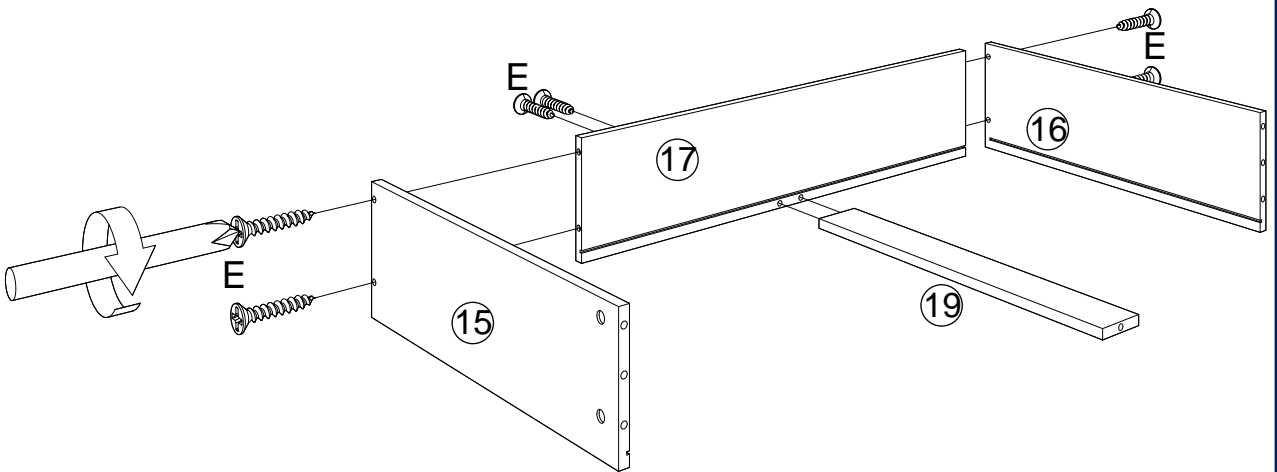

X2

STEP 17:

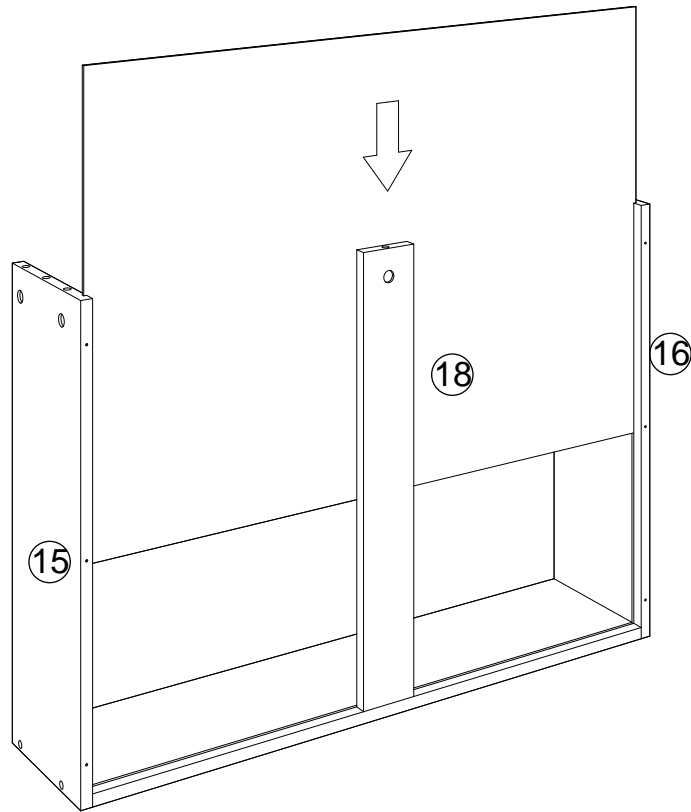

X2

STEP 18:

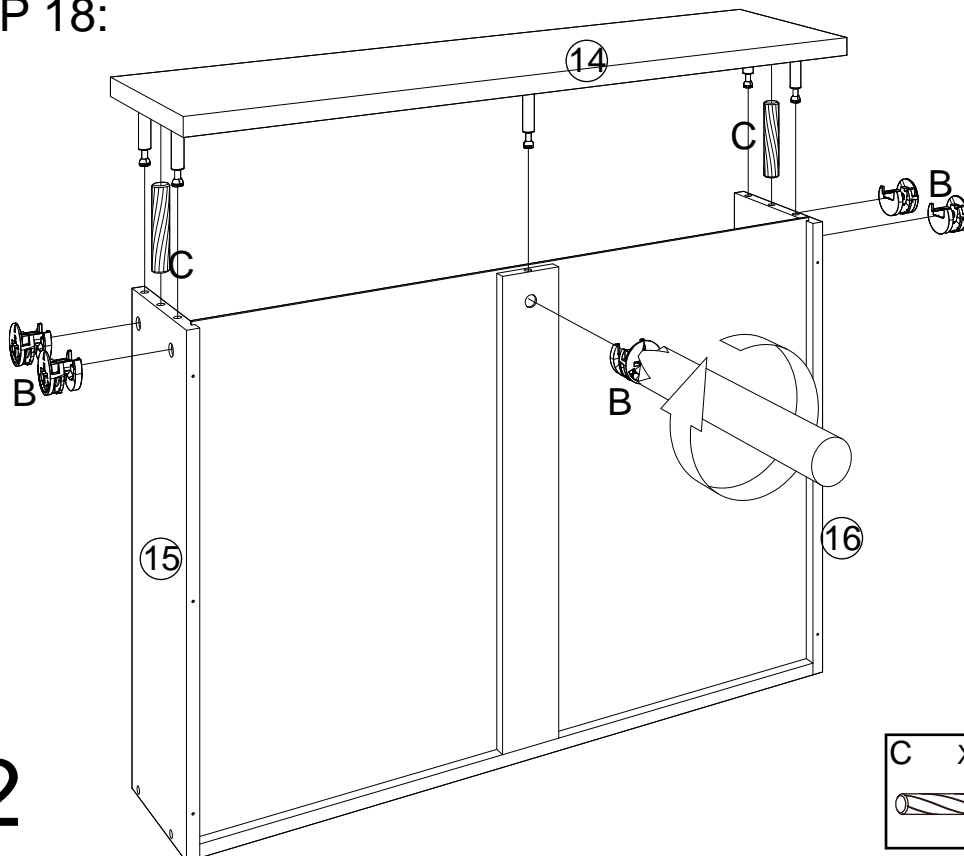

X2

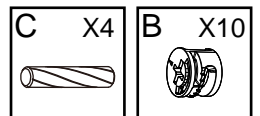

STEP 19:

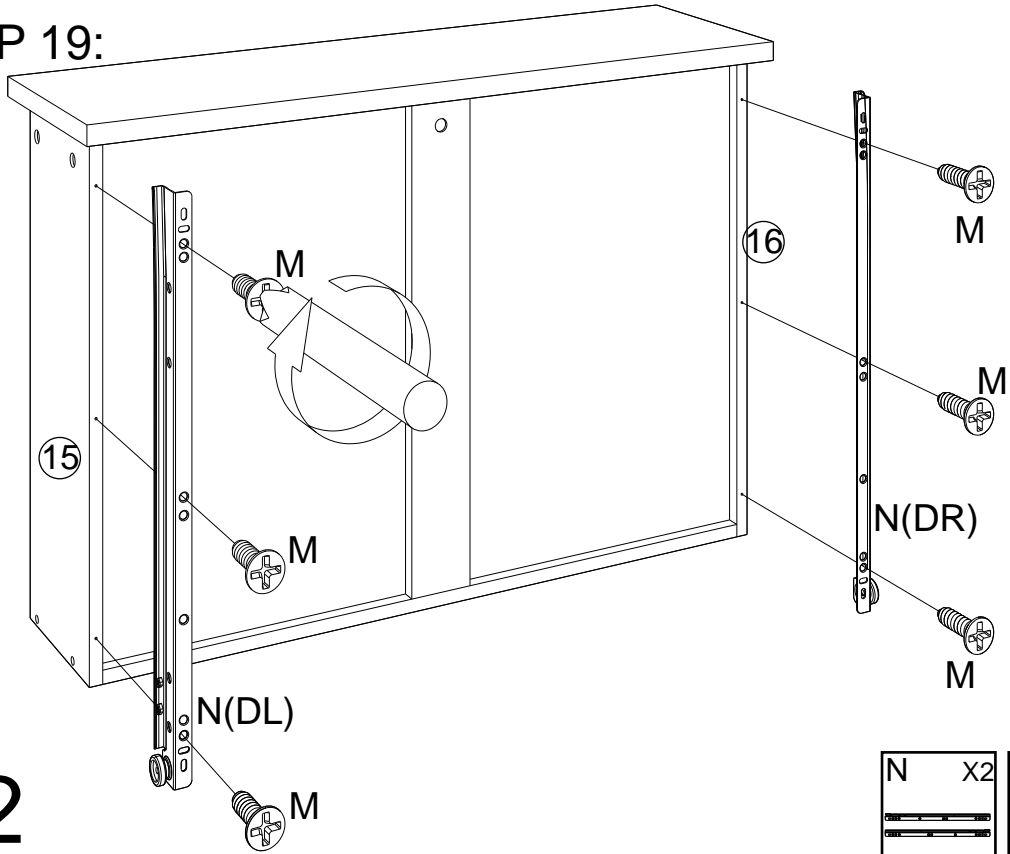

X2

STEP 20:

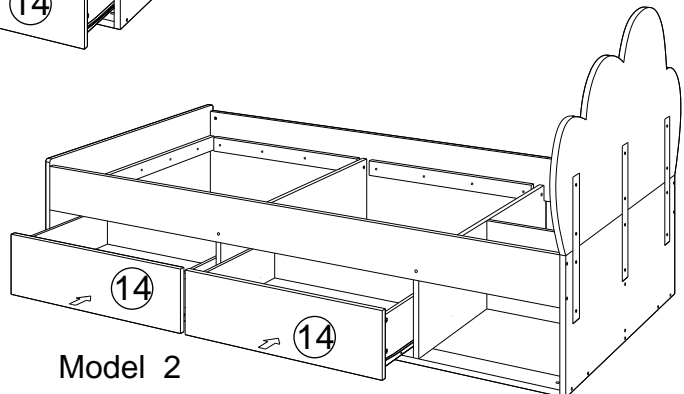
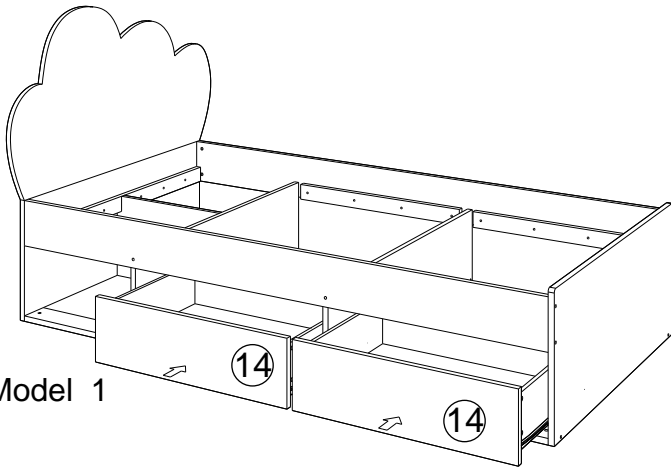
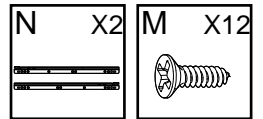

STEP 21:

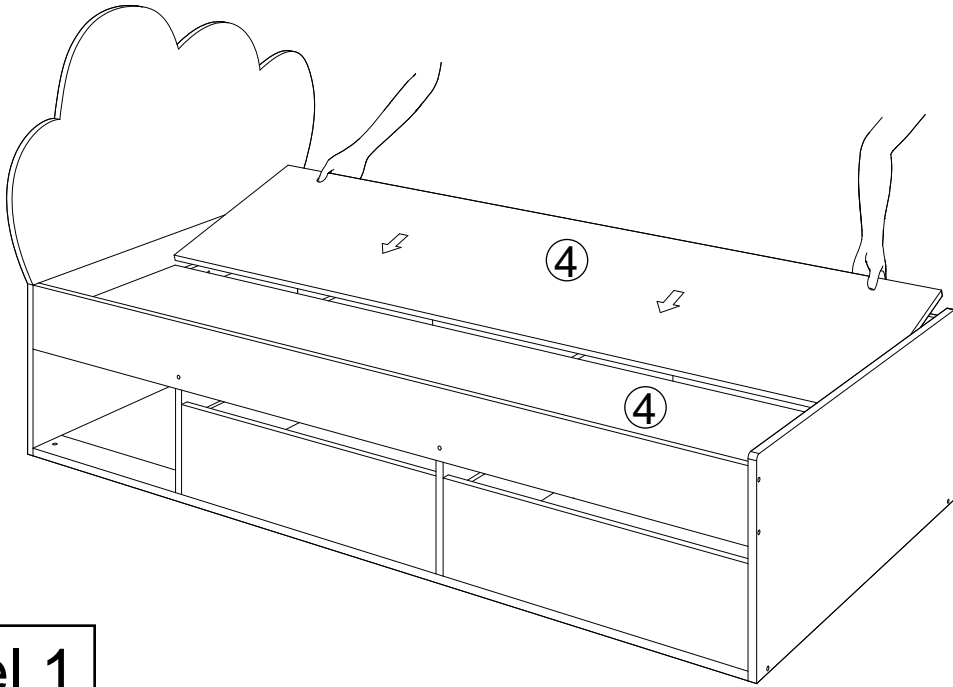

Model 1

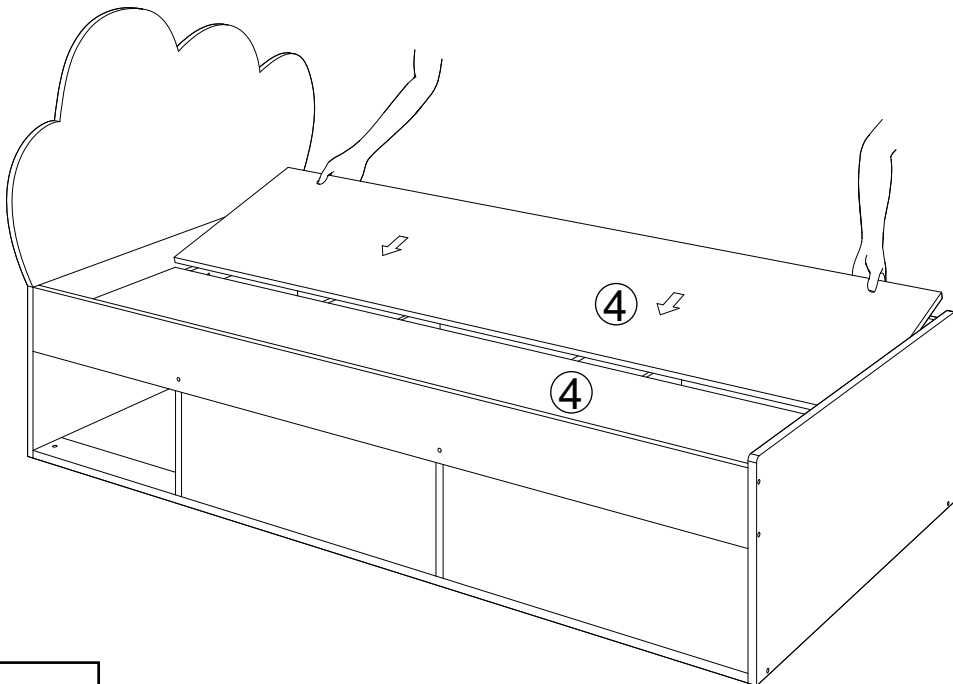

Model 2

STEP 22:

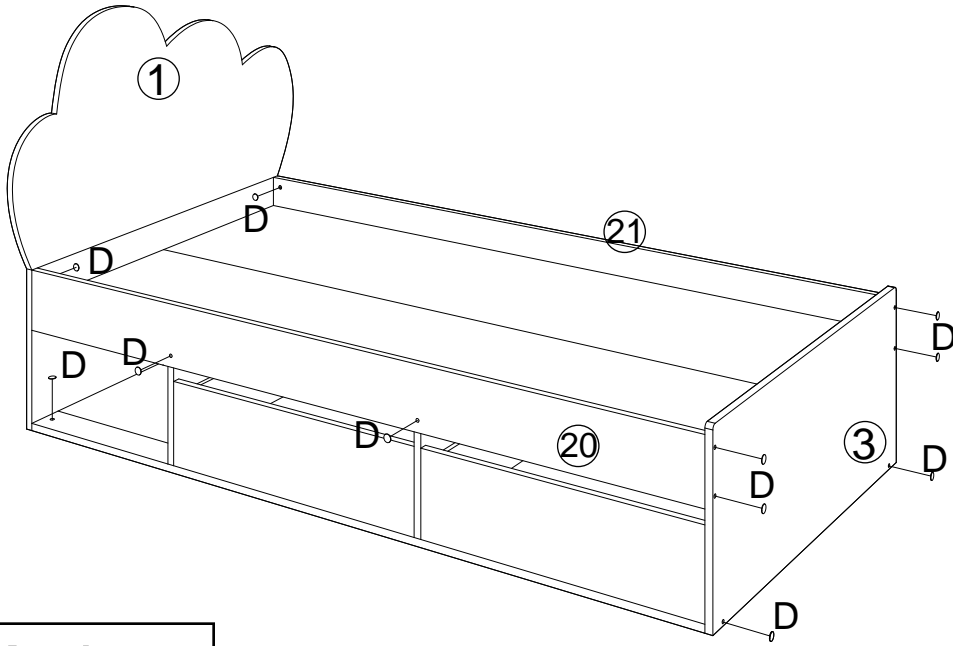
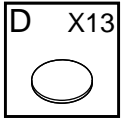

Model 1

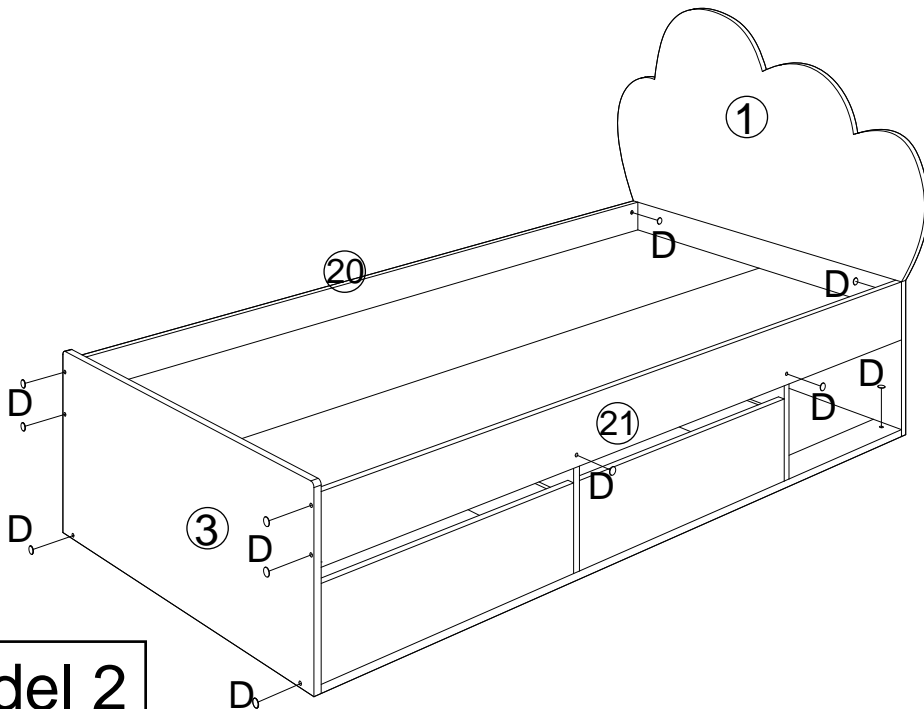

Model 2

ASSEMBLY IS COMPLETE

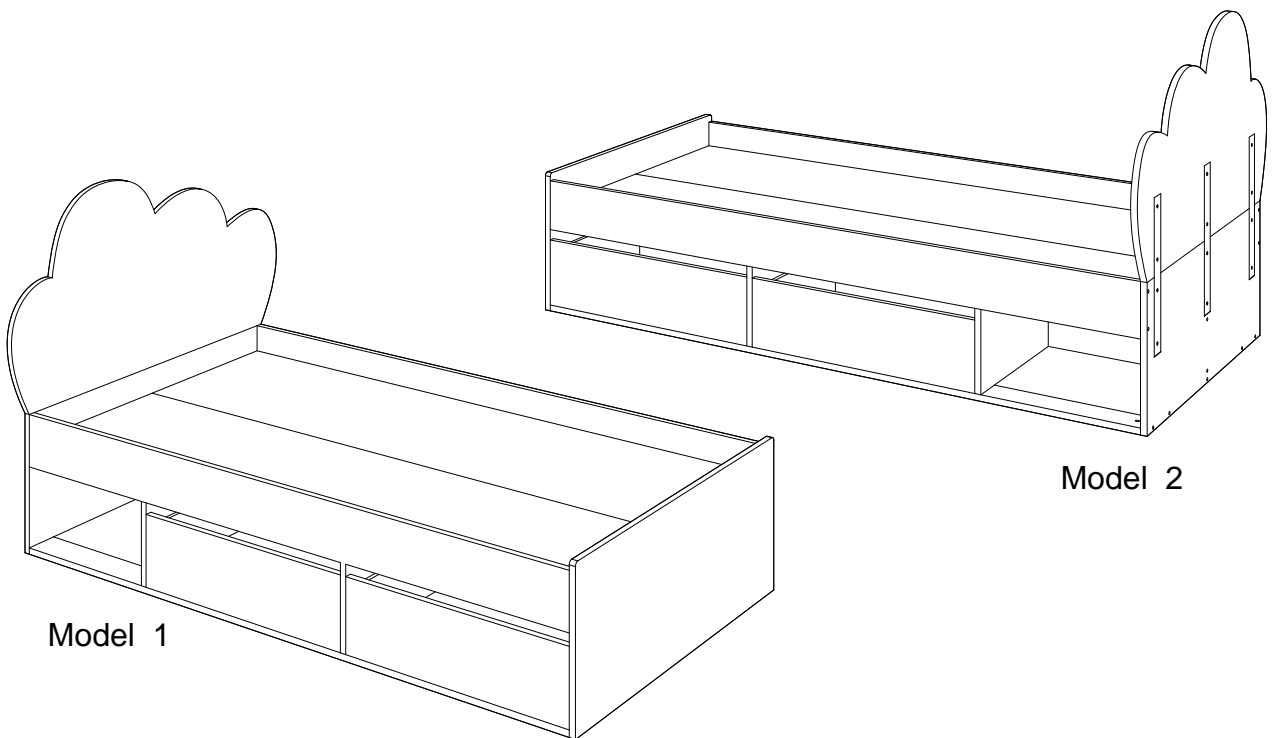

Model 1

Model 2

CAUTION: Always Lift Your Furniture When Moving /Relocating - Do Not Drag. Dragging Can Cause The Legs To Bend/Break.

To protect your furniture, we suggest the following:

- Avoid placing your furniture in direct sunlight.
- Do not place furniture directly under windows.
- Do not place sharp materials (knife, fork, etc.) directly onto your furniture as sharp material may scrape and damage the finish.
- Do not place material with high temperature directly onto the surface of your furniture.
- Clean up spills quickly. Water left over a prolonged period of time may cause damage. Alcohol, perfume, nail polishes, aftershave and some medication may cause severe finish damage if not cleaned immediately.
- Use a clean, soft, dry, lint free absorbent cloth to clean your furniture. Do not use any detergent as they may contain ingredients that may react and damage the finish.

NOTE: If the above care advise is not adhered to your product warranty may become void