

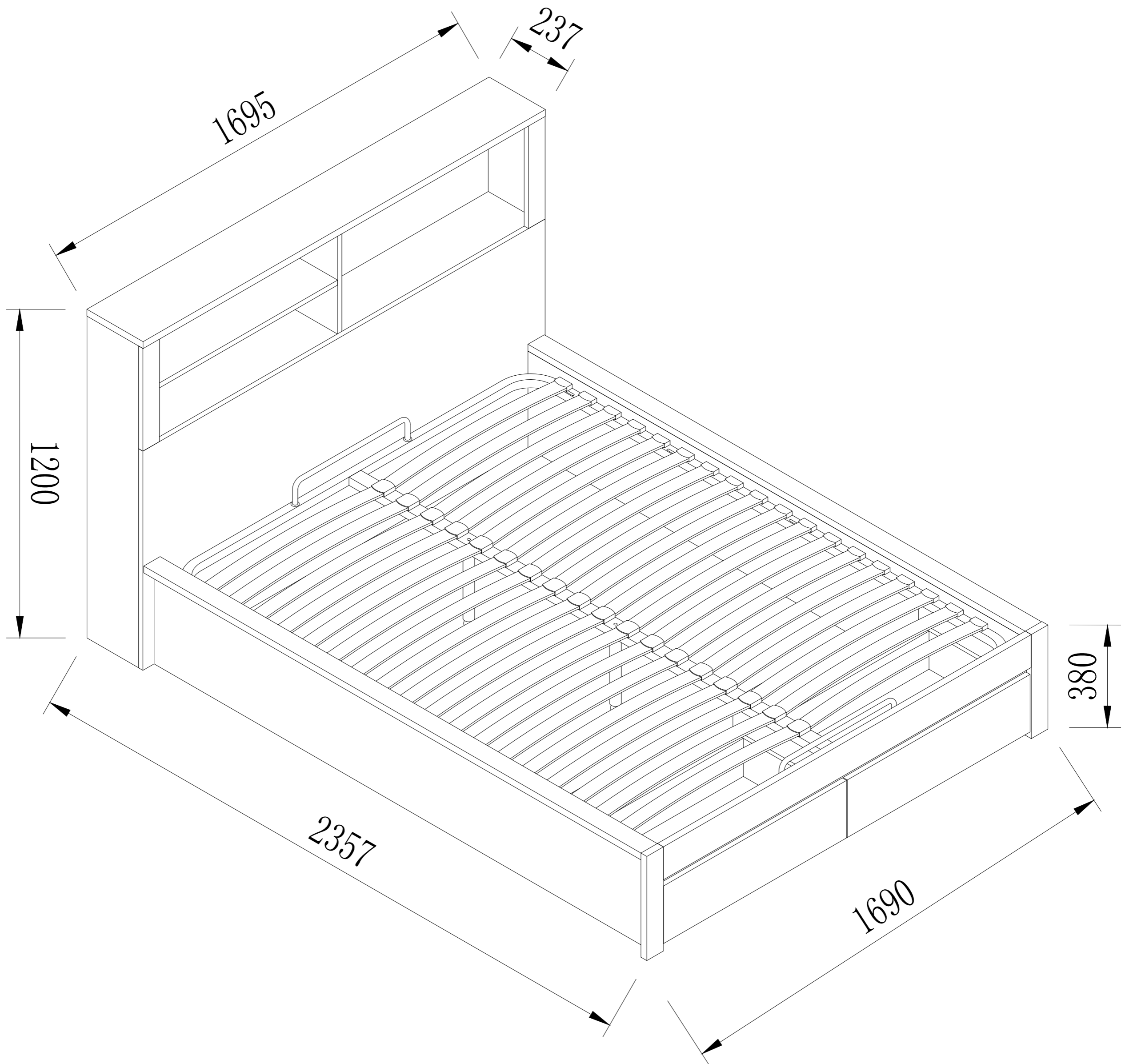

ASSEMBLY INSTRUCTION

COLWYN BAY QUEEN LIFT BED

ITEM CODE 82505



Imported by Amart Furniture Pty Ltd. Qld. Brisbane Australia.
For any assistance with assembly or for missing parts please phone Amart Furniture
Customer Service Free call 1800 351 084

PRE-ASSEMBLY PREPARATION

Before you start:

1. Choose a clean, level, spacious assembly area. Avoid hard surfaces that may damage the product
2. Take care when lifting. Product should be assembled as near as possible to the point of use
3. Ensure that you have all required contents for complete assembly.
4. Always read the assembly instructions carefully before beginning assembly.
5. Keep all hardware parts and packaging out of reach of small children.
6. Do not over tighten the screws and bolts as this may damage the threads

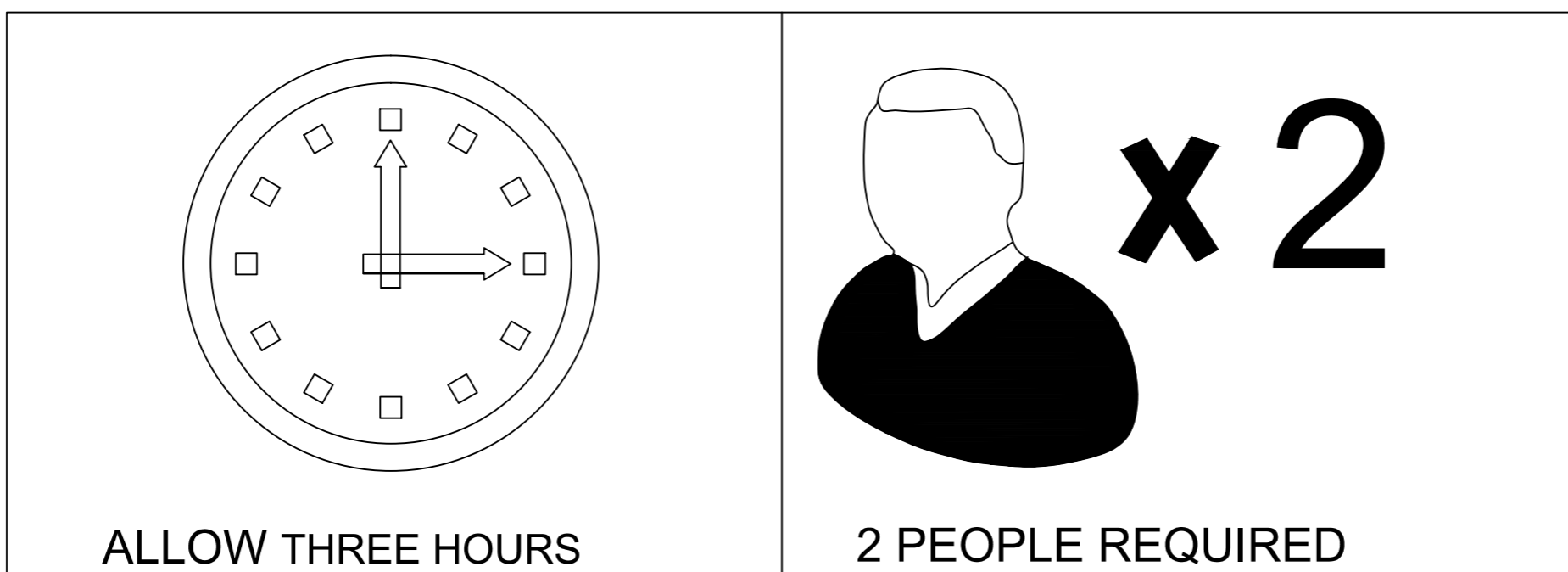

WARNING



Do not allow children to play on this mechanised furniture or operate the mechanism. Ensure that the mattress and lift mechanism has been returned to the lowered position before lying or sitting on the mattress. Always ensure that your body is clear of the lift mechanism when lifting and lowering the mechanism

CAM Lock and Pins

step 1

HOW TO USE CAM LOCK FASTENERS

To assemble this product hardware called Cam Lock Fasteners are used. The below is information on how these work.

Cam Locks are fasteners used to join two boards together, usually the edge of one board(A) to the flat side of another board(B)

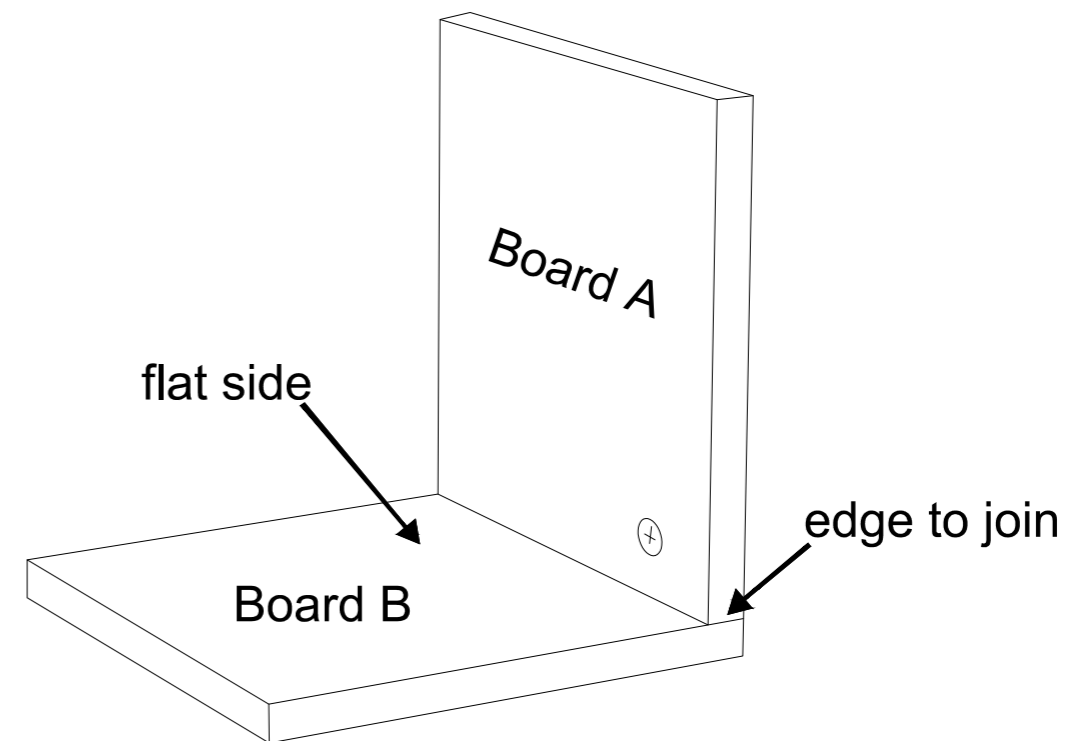
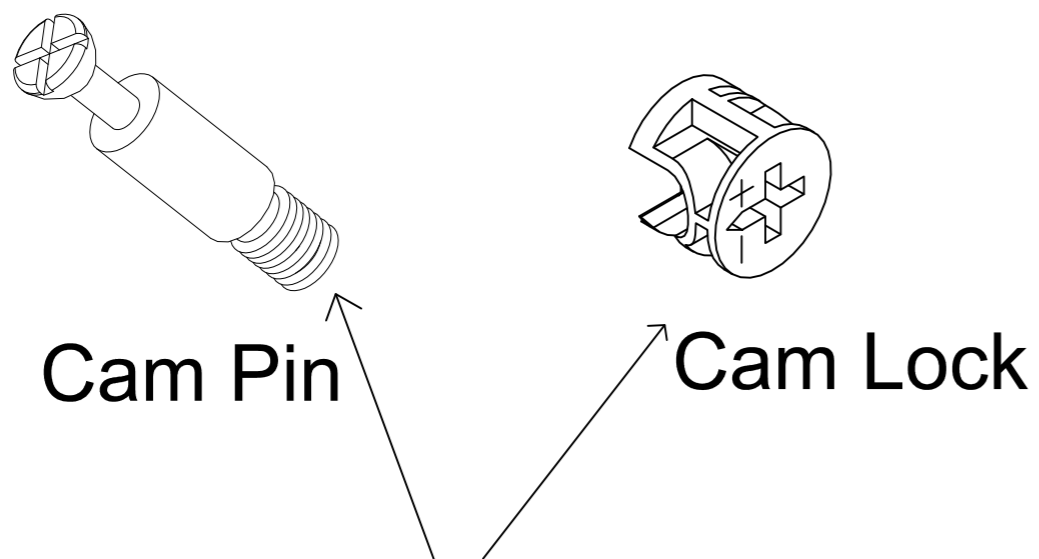

Ensure that you use the correct images that are representative of the hardware used in the product

step 2

To use Cam Lock Fasteners

The Cam Pin is inserted into the flat side of a board, it is important that:

- * The cam pin is kept vertical and is not put in on an angle
- * Cam Pin is inserted up to the collar
 - * Too far and it wont catch the Cam Lock (Do not Over Tighten)
 - * Not enough and the resulting product wont be stable

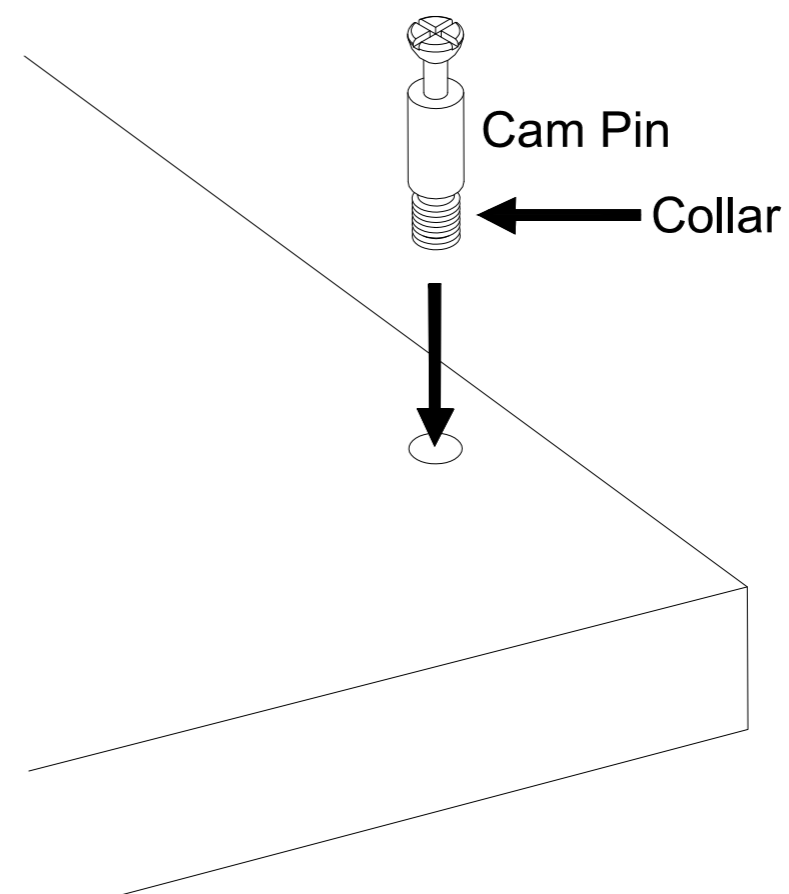

step 3

To use Cam Lock Fasteners

Now fit the hole in the edge of the joining board over the Cam Pin

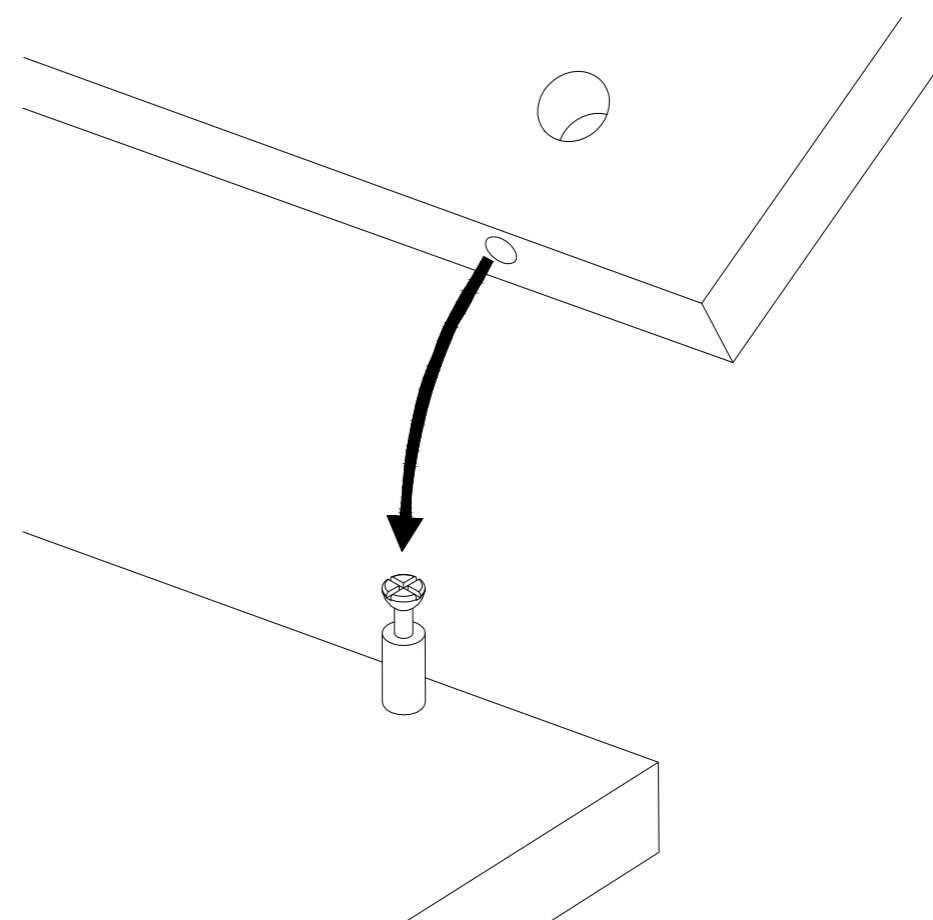

step 4

To use Cam Lock Fasteners

The Head of the Cam Pin will be visible in the large hole on the side of the joining board

head of the Cam Pin

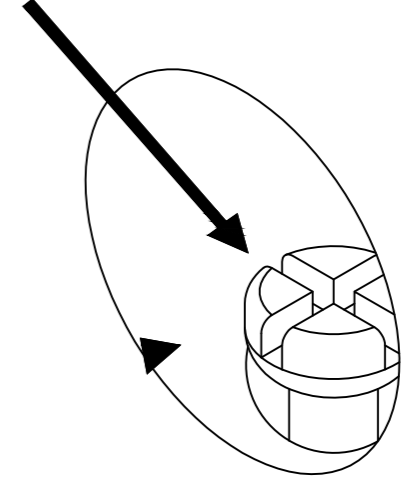

To use Cam Lock Fasteners

Notice the Cam Lock has a "C" Shaped back An Arrow or +/- signs on the front, indicated the open section on the back of the Cam Pin

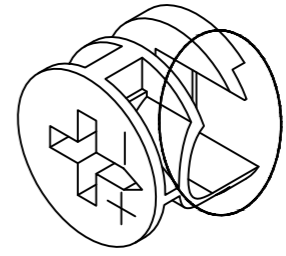

Cam Lock

step 5

To use Cam Lock Fasteners

In sert the Cam Lock into the large hole so the opening of the "C" fits over the head of the Cam Pin. You must ensure that the Cam Lock is pushed to the bottom of the hole to catch the top of the Cam Pin

Arrow or +/- signs

head of the Cam Pin

Open section of back fits over the head of the Cam Pin

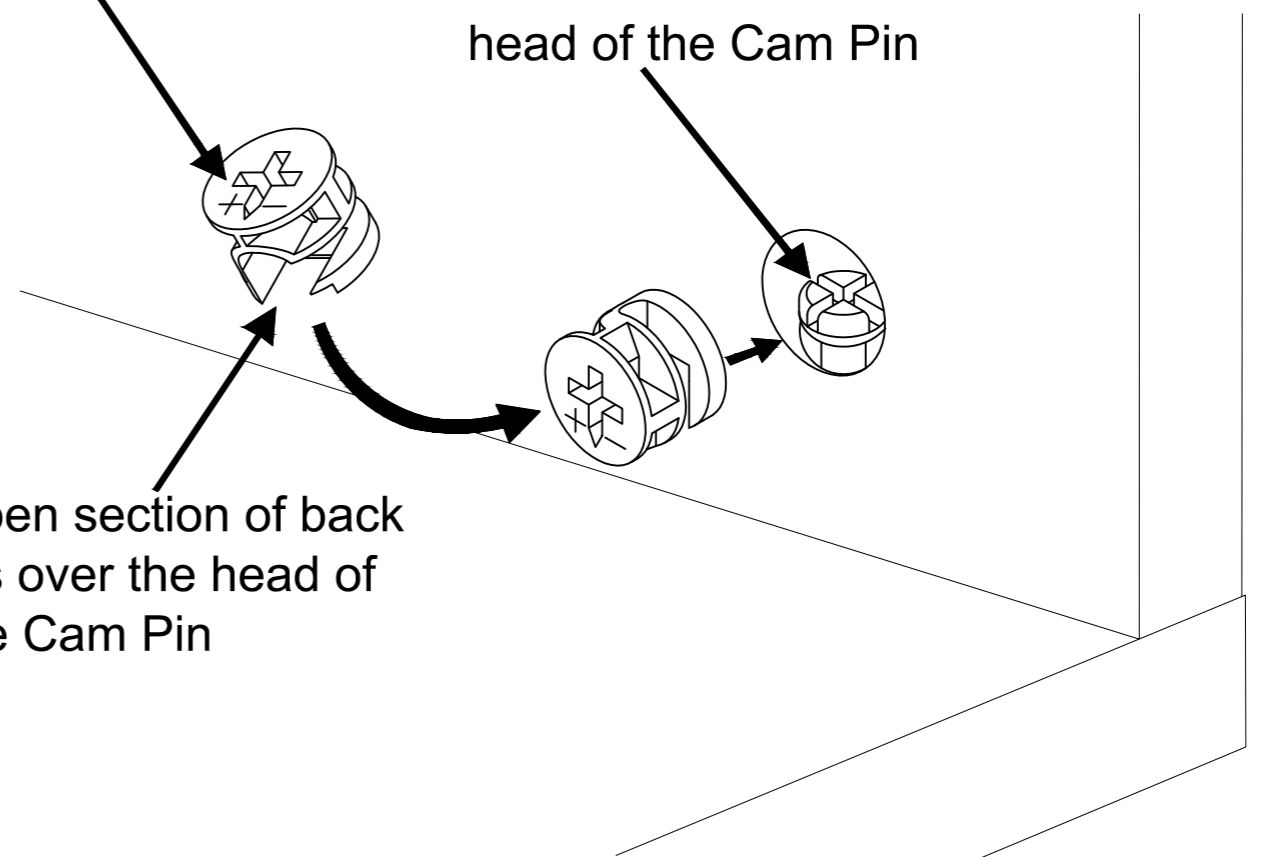

step 6

To use Cam Lock Fasteners



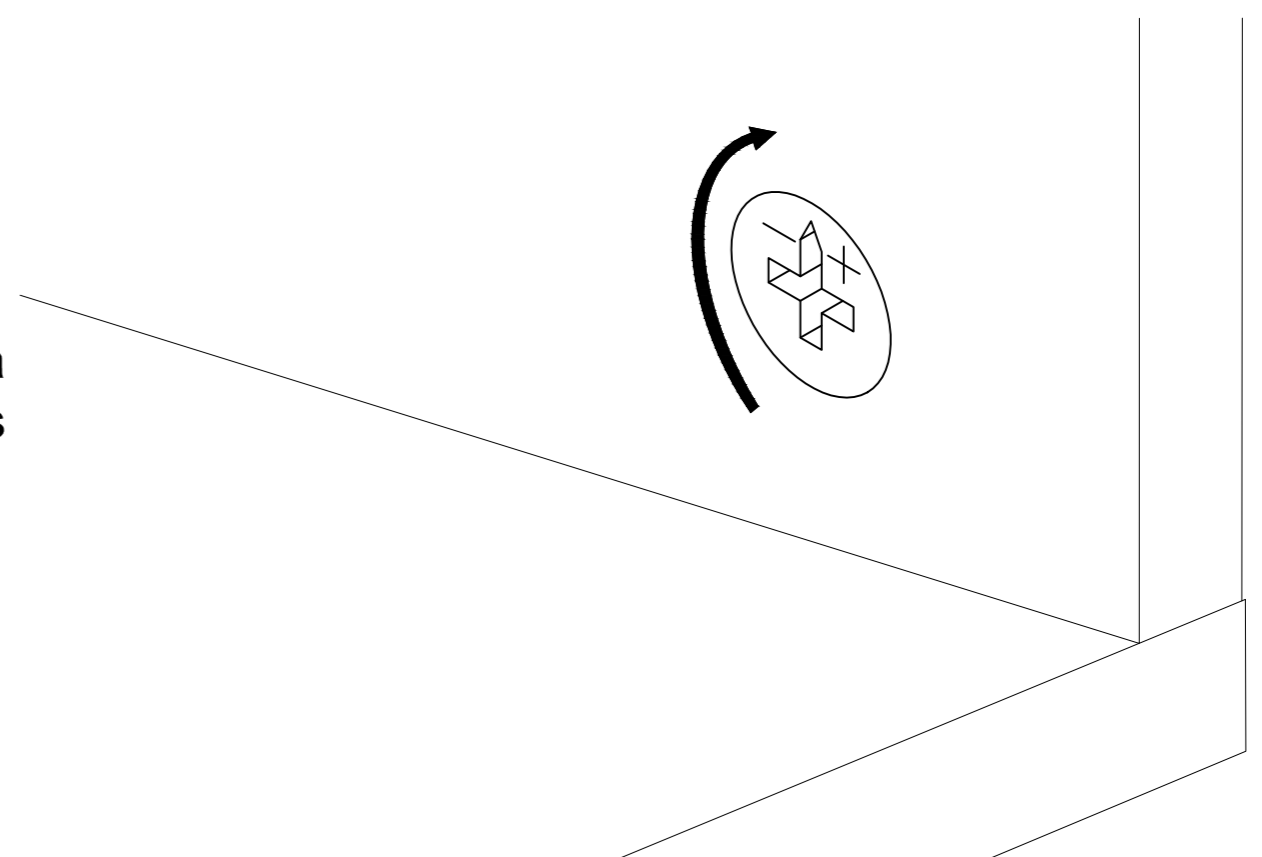



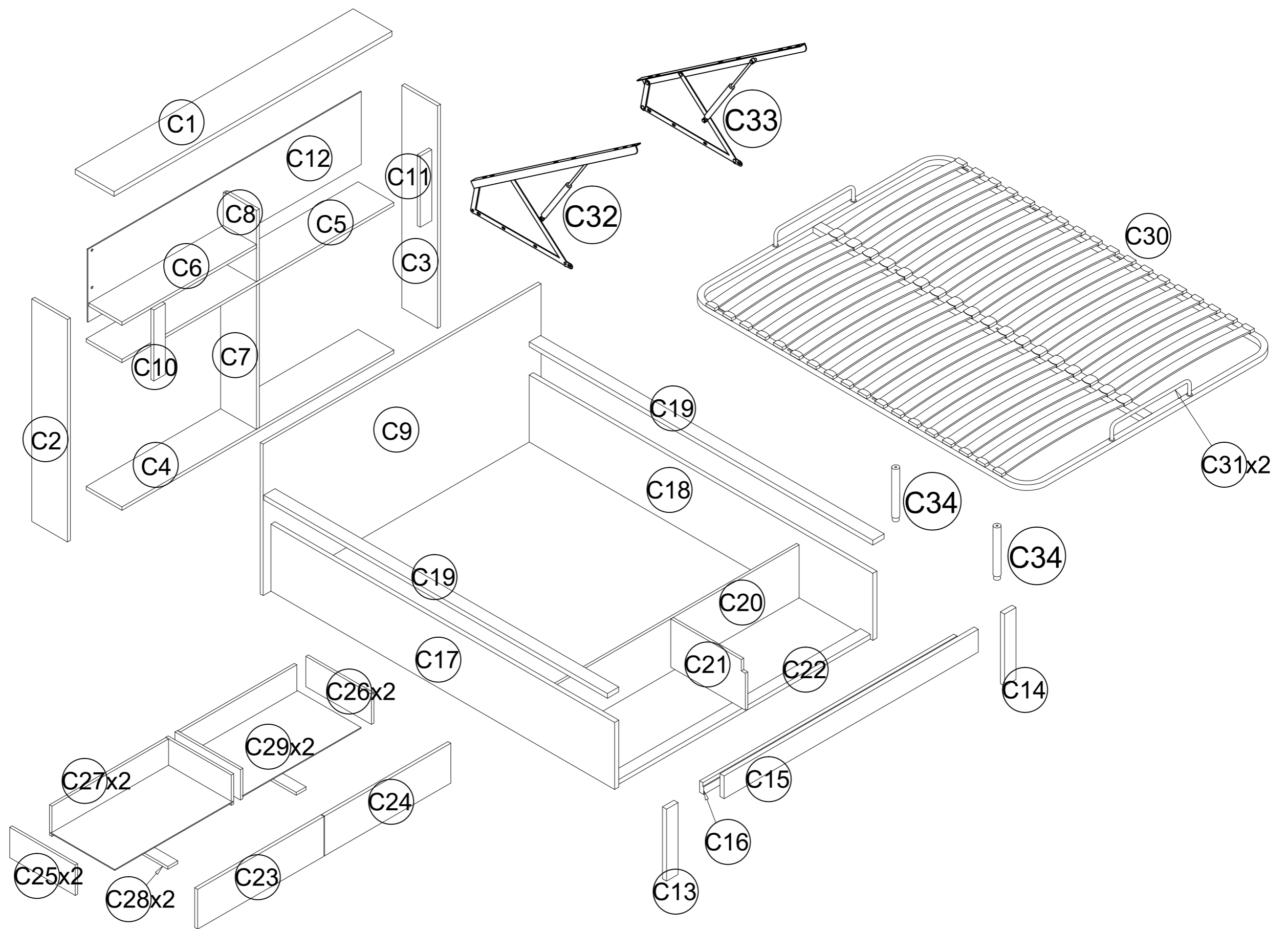

Use a flat screwdriver to turn the Cam Lock clockwise one half a turn so it Locks onto the head of the Cam Pin. Turn only until it is snug-over-tightening could cause the Cam to bend or break. If it will not turn the full amount, turn the Cam Pin out (counter-clockwise) one full turn, and try the Cam Lock again.

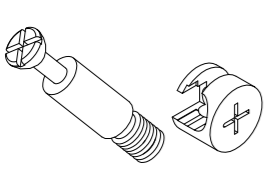
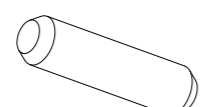
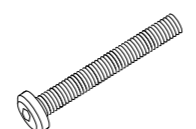
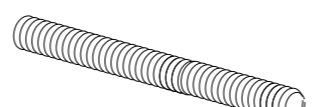
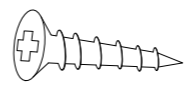
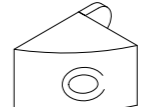
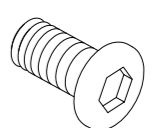
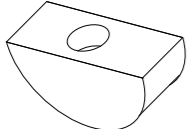
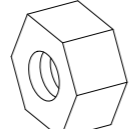

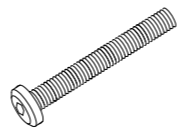
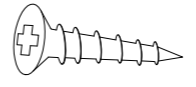
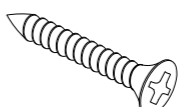
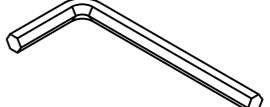
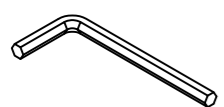
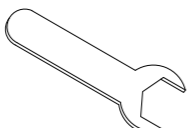
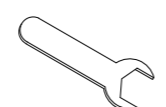
PARTS LIST

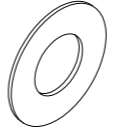

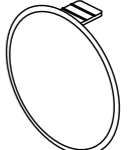
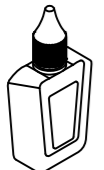
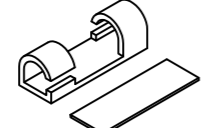
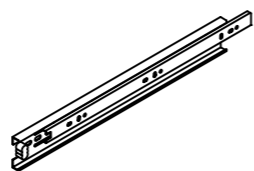
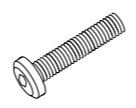
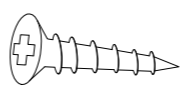
| | | | |
|------|---------------------|-----|-------------------------|
| C1 | Top Panel | C21 | Support Panel |
| C2 | Left Side Panel | C22 | Connect Panel |
| C3 | Right Side Panel | C23 | Drawer Front Panel |
| C4 | Bottom Panel | C24 | Drawer Front Panel |
| C5 | Shelf Panel | C25 | Drawer Left Side Panel |
| C6 | Shelf Panel | C26 | Drawer Right Side Panel |
| C7 | Support Panel | C27 | Drawer Back Panel |
| C8 | Support Panel | C28 | Connect Panel |
| C9 | Back Panel | C29 | Bottom Panel |
| C10 | Support Panel | C30 | Slate |
| C11 | Support Panel | C31 | Handle Panel |
| C12 | Back Panel | C32 | Gas Lift |
| C13 | Let Connect Panel | C33 | Gas Lift |
| C14 | Right Connect Panel | C34 | Middle Leg |
| C15 | Front Panel | | |
| C16 | Front Rail | | |
| C17 | Left Side Panel | | |
| C18 | Right Side Panel | | |
| C19a | Side Rail | | |
| C20b | Support Panel | | |

| | | | | | | |
|---|---|--|---|---|---|---|
| A. Cam lock and Cam pin Ø15X35 <input type="checkbox"/> | B. Dowel Ø8X30 <input type="checkbox"/> | C. Bolt M8x80 <input type="checkbox"/> | D. Bolt M8x75 <input type="checkbox"/> | E. Screw Ø3X18 <input type="checkbox"/> | F. Connector <input type="checkbox"/> | G. Bolt M8x20 <input type="checkbox"/> |
|  79PCS |  40PCS |  4PCS |  6PCS |  6PCS |  6PCS |  8PCS |
| H. Half Round Nuts M8 <input type="checkbox"/> | I. Hexagonal Nuts M8 <input type="checkbox"/> | J. Hexagonal Nuts M6 <input type="checkbox"/> | K. Bolt M6x50 <input type="checkbox"/> | L. Screw Ø3.5X14 <input type="checkbox"/> | M. Screw Ø3.5X30 <input type="checkbox"/> | N. Hex Key 5MM <input type="checkbox"/> |
|  10PCS |  10PCS |  6PCS |  10PCS |  24PCS |  12PCS |  1PCE |
| O. Hex Key 4MM <input type="checkbox"/> | P. Wrench M14 <input type="checkbox"/> | Q. Wrench M10 <input type="checkbox"/> | R. Washer Ø13 <input type="checkbox"/> | S. Washer Ø16 <input type="checkbox"/> | T. Protect foam 20x14x5mm <input type="checkbox"/> | U. Cover Ø38 <input type="checkbox"/> |
|  1PCE |  1PCE |  1PCE |  12PCS |  12PCS |  20PCS |  10PCS |
| V. Glue <input type="checkbox"/> | W. Clip&Sticker <input type="checkbox"/> | X. Runner 350mm <input type="checkbox"/> | Y. Bolt M8x45 <input type="checkbox"/> | Z. Screw Ø4X45 | Z1. Screw Ø4X45 | |
|  1PCE |  4PCS |  2PCS |  2PCS |  5PCS |  1PCS | |

STEP 1:

Runner slide separately($H=H1+H2$)

Carefully pull out the runner slide($H2$) and press plastic clip to fully separate runner slide as diagram shown

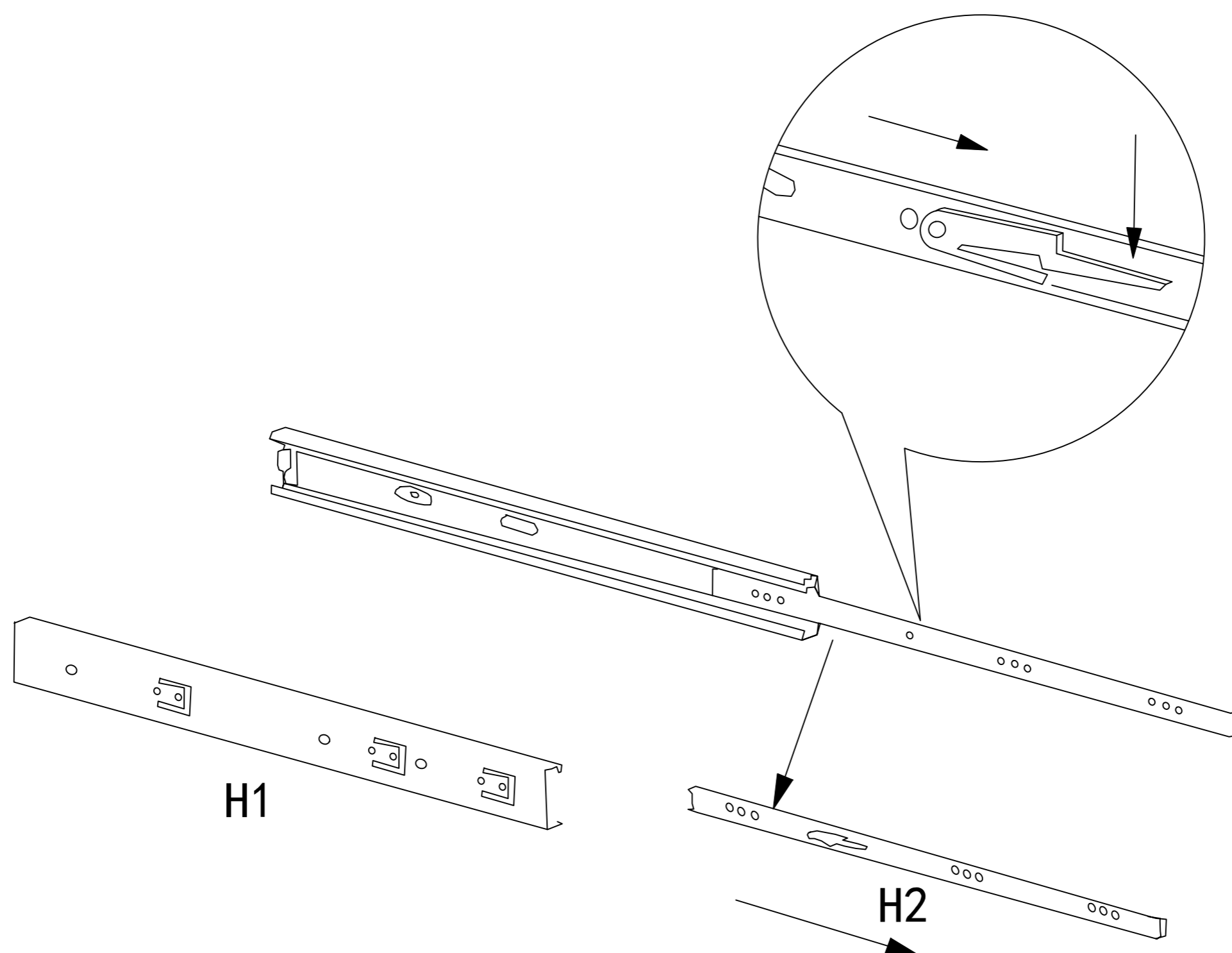

82505

Step 2: Insert Cam Pin(A) and Dowel(B) into Panel(C1&C4&C5).

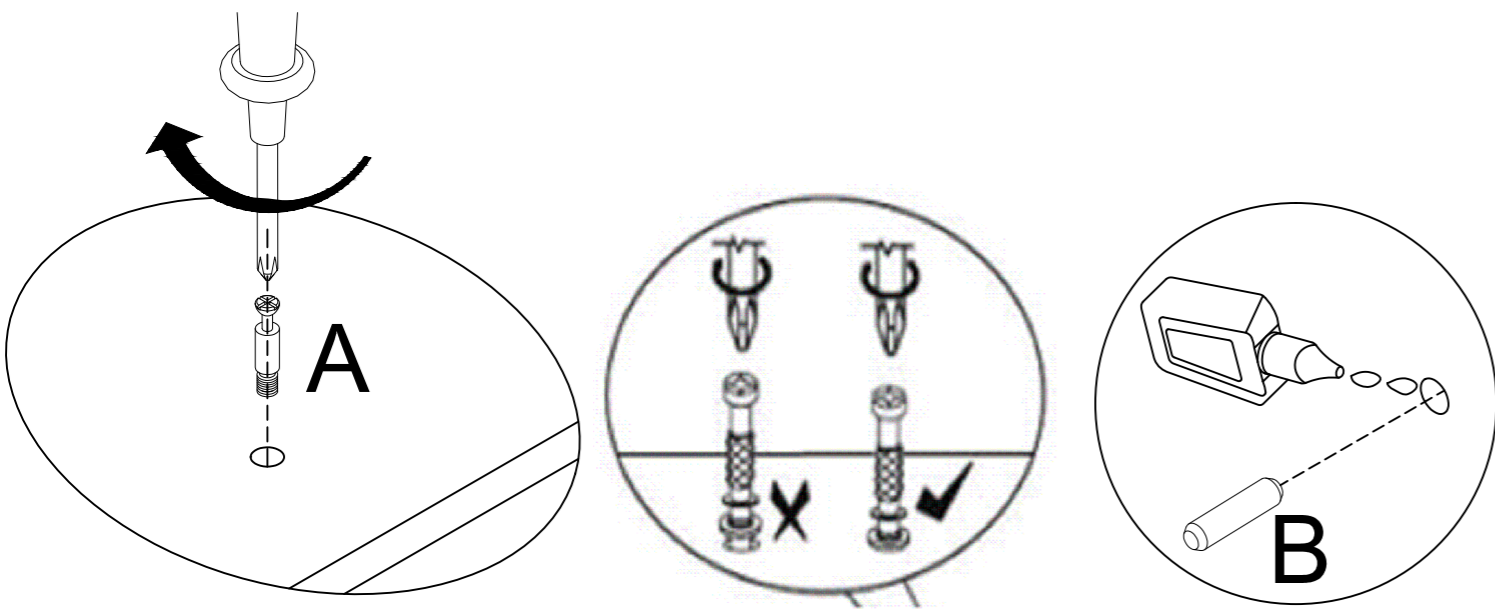
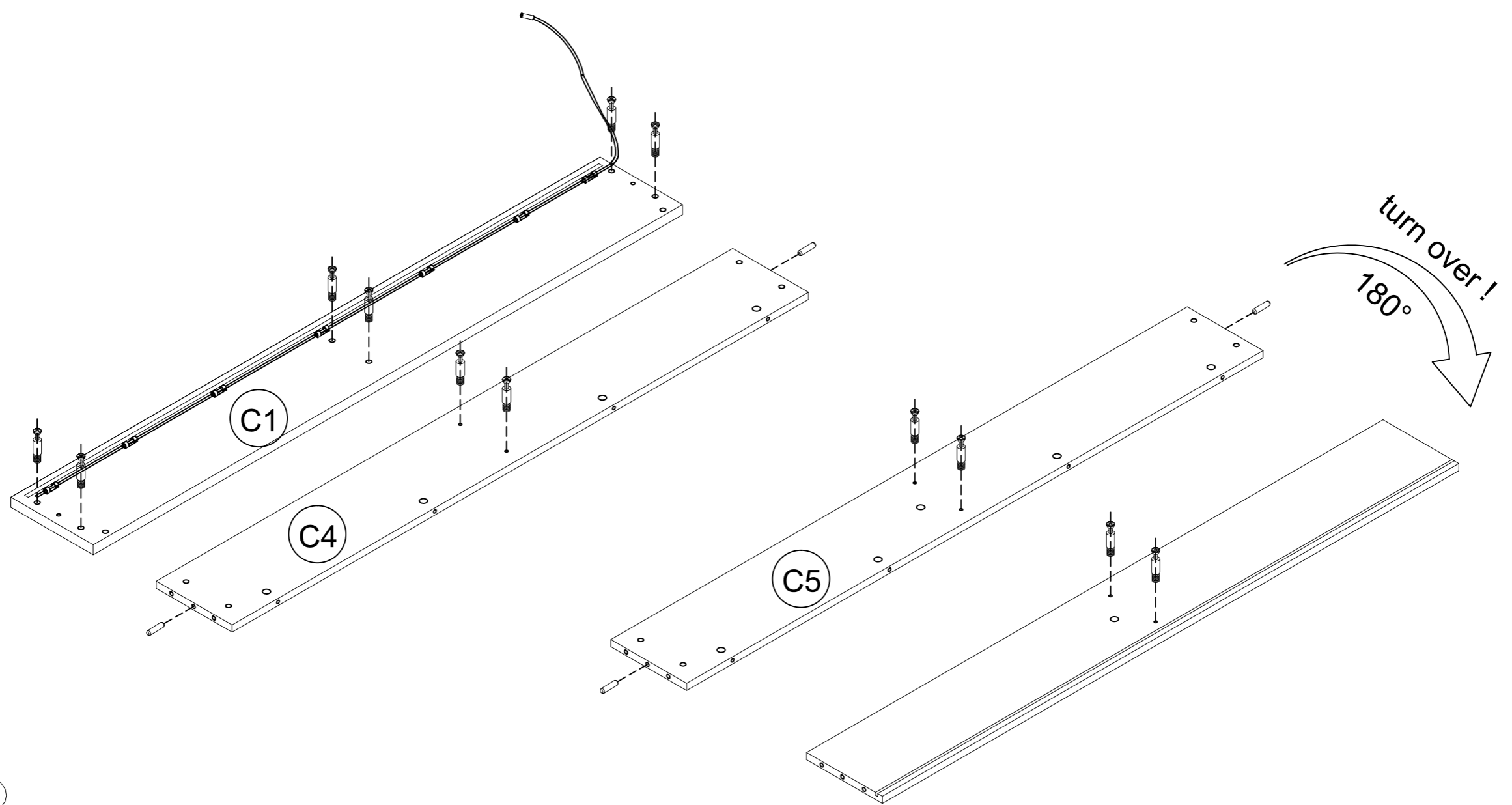

Step 3: Insert Cam Pin(A) into Panel(C9).

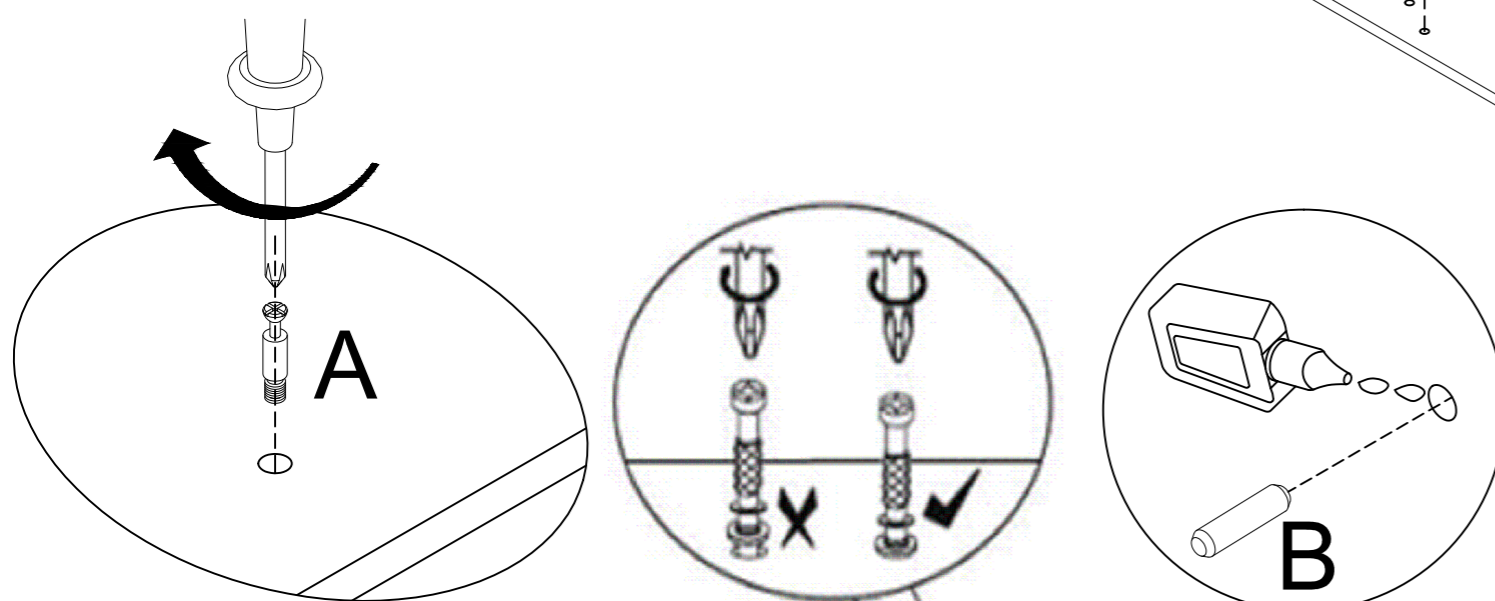
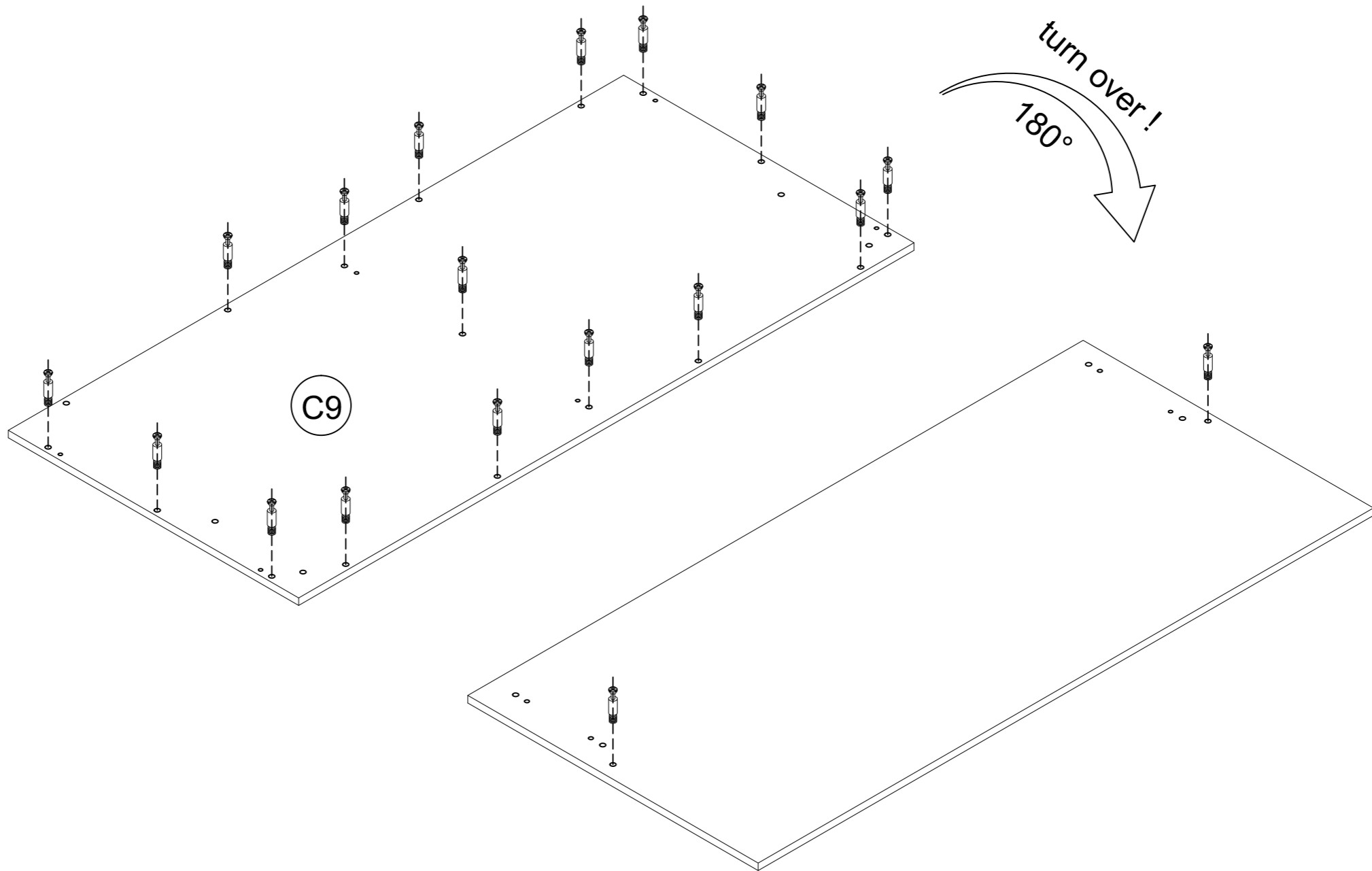

82505

Step 4: Insert Cam Pin(A) and Dowel(B) into Panel(C2&C3&C6&C7&C8&C10&C11).

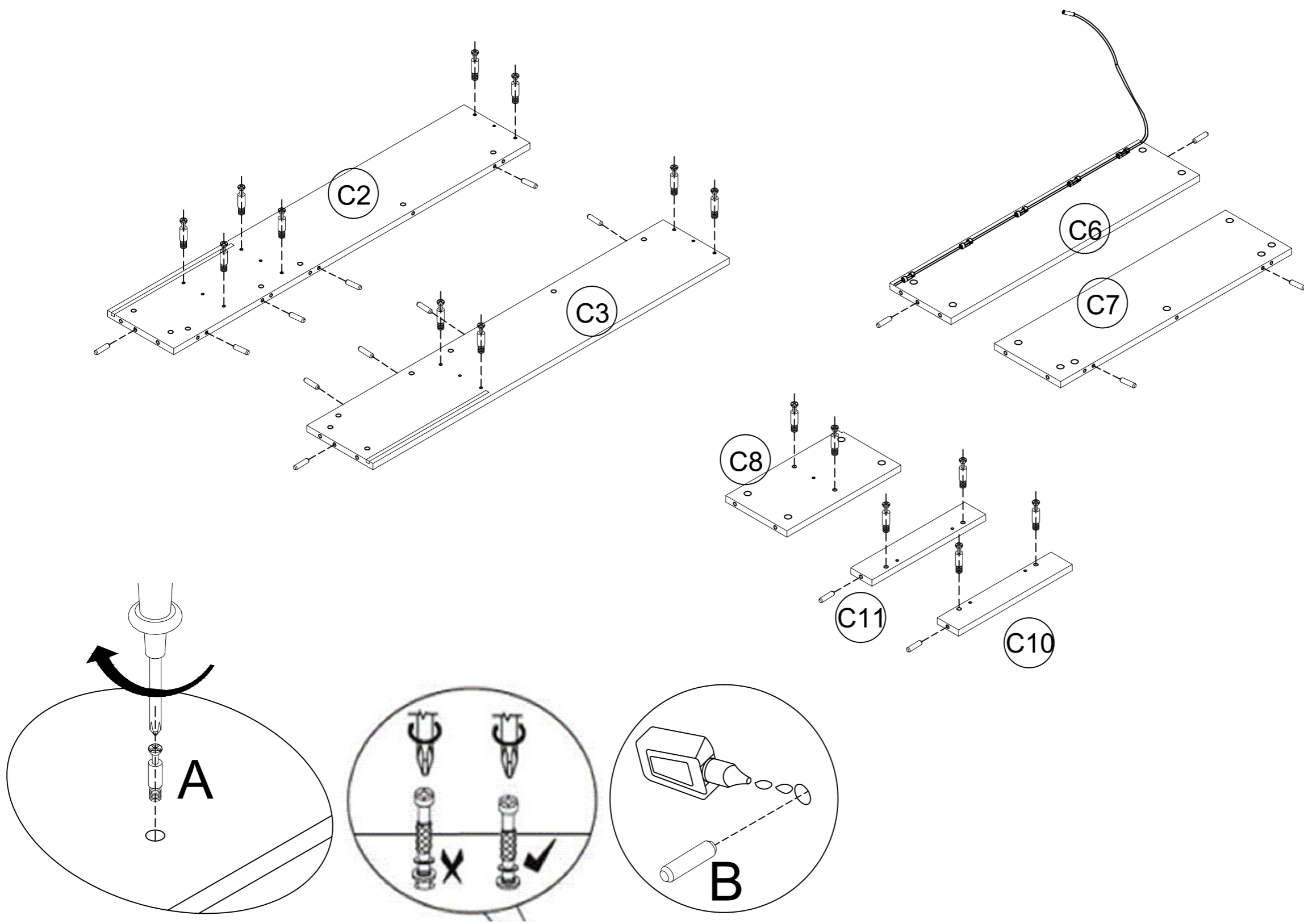

Step 5: Insert Cam Pin(A) and Dowel(B) into Panel(C17&C18&C19). Attach Runner(X) to Panel(C17&C18&C21) with Screw(L). Attach Protect Foam(T) to Panel(C17&C18).

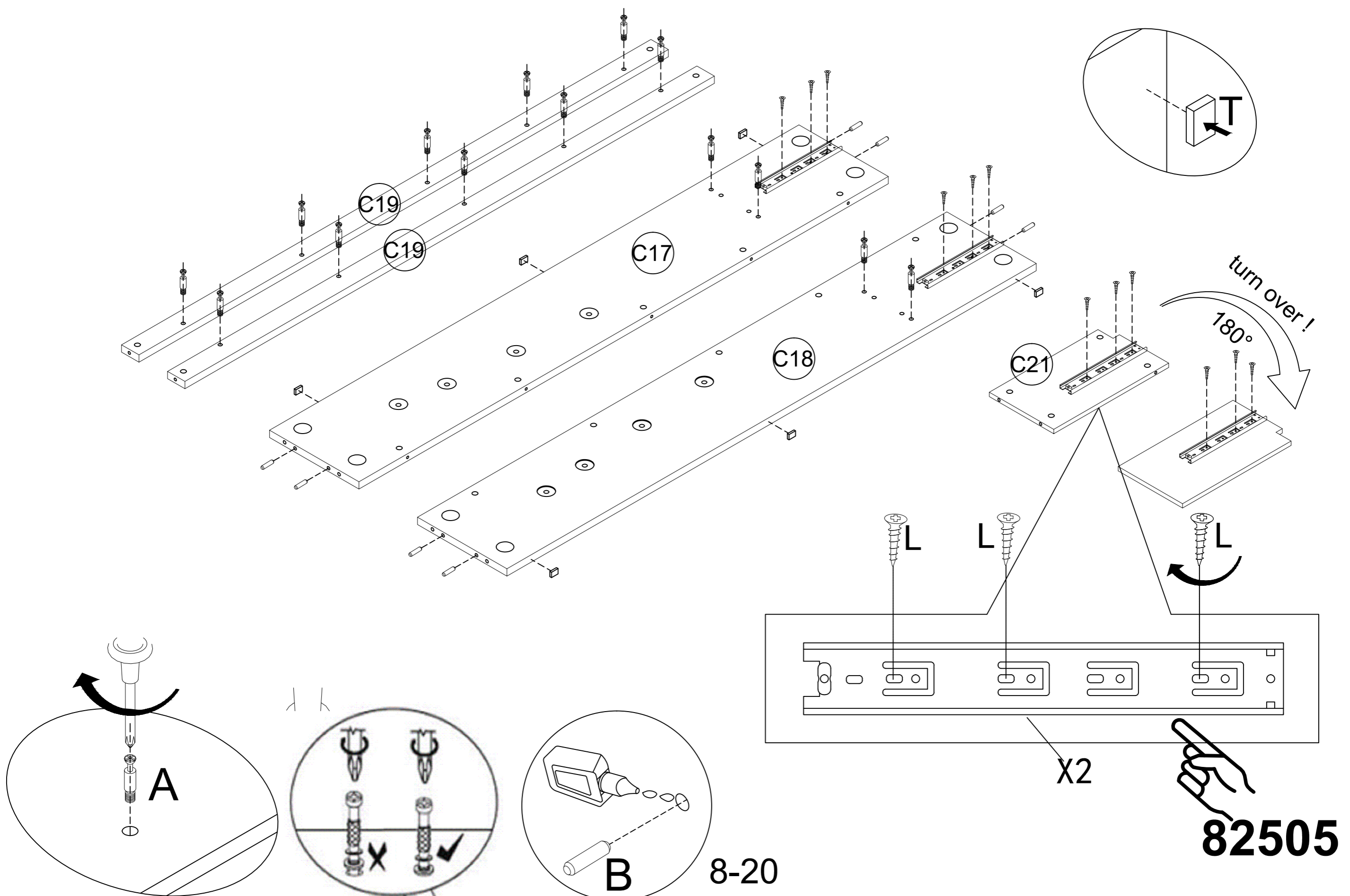

8-20

82505

Step 6: Insert Cam Pin(A) and Dowel(B) and Bolt(D) into Panel(C13&C14&C20&C22&C23&C24).

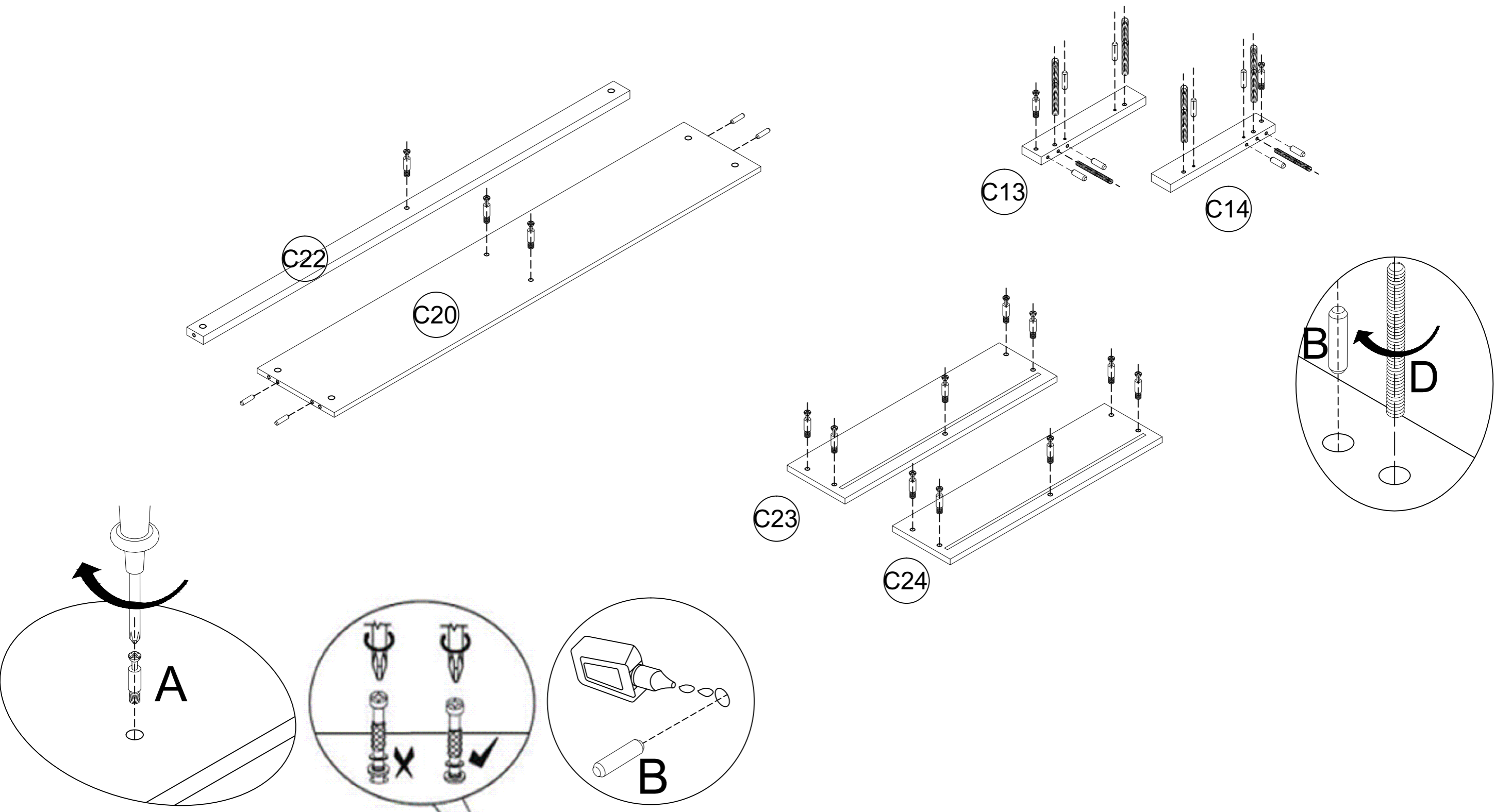

Step 7: Attach Panel(C4&C5) to Panel(C7&C8). And turn Cam Lock(A) to lock into the head of Cam Pin(A).

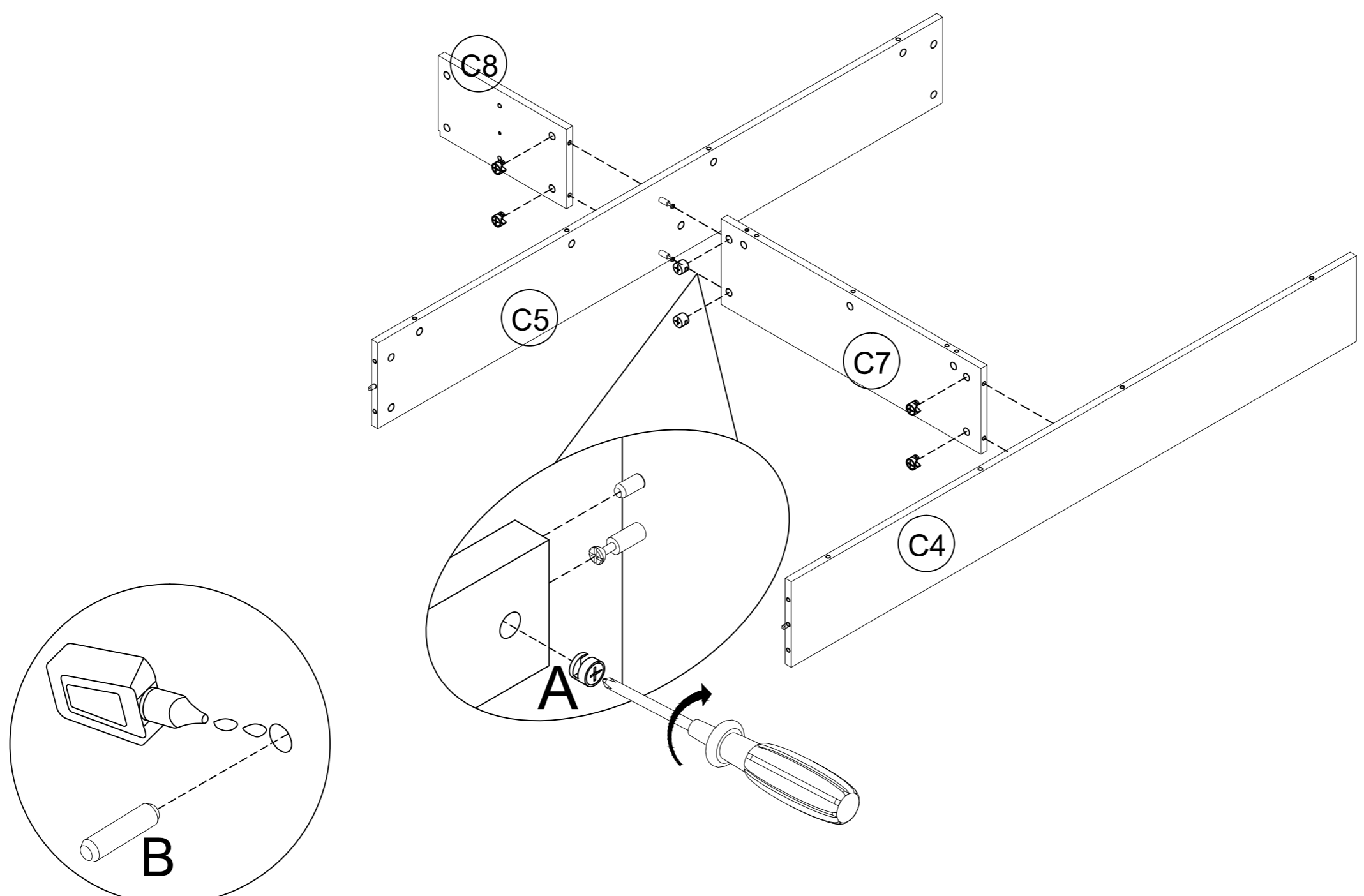

82505

Step 8: Attach Panel(C6) to Panel(C8). And turn Cam Lock(A) to lock into the head of Cam Pin(A).

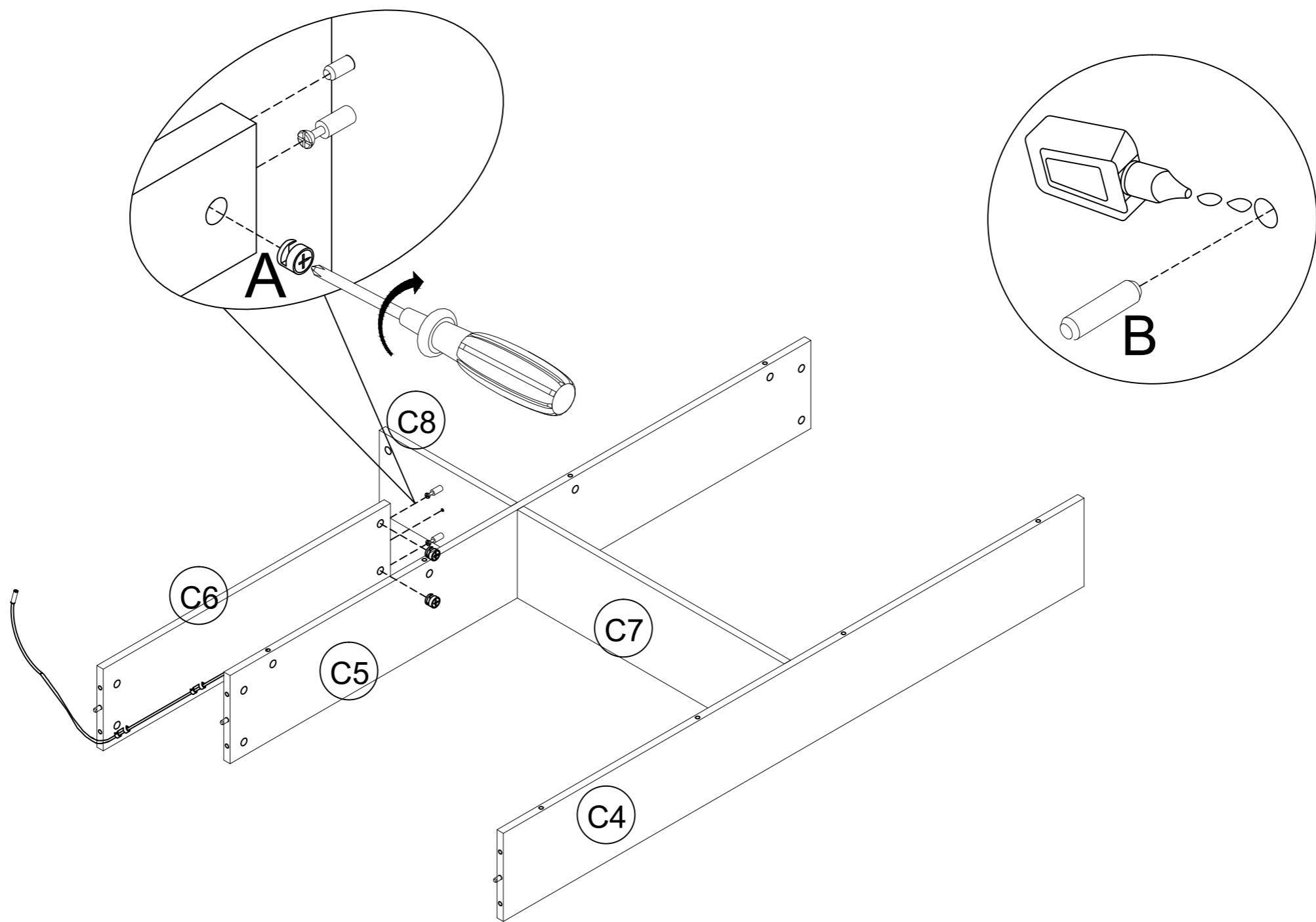

Step 9: Attach Panel(C2&C3) to Panel(C4&C5&C6). And turn Cam Lock(A) to lock into the head of Cam Pin(A).

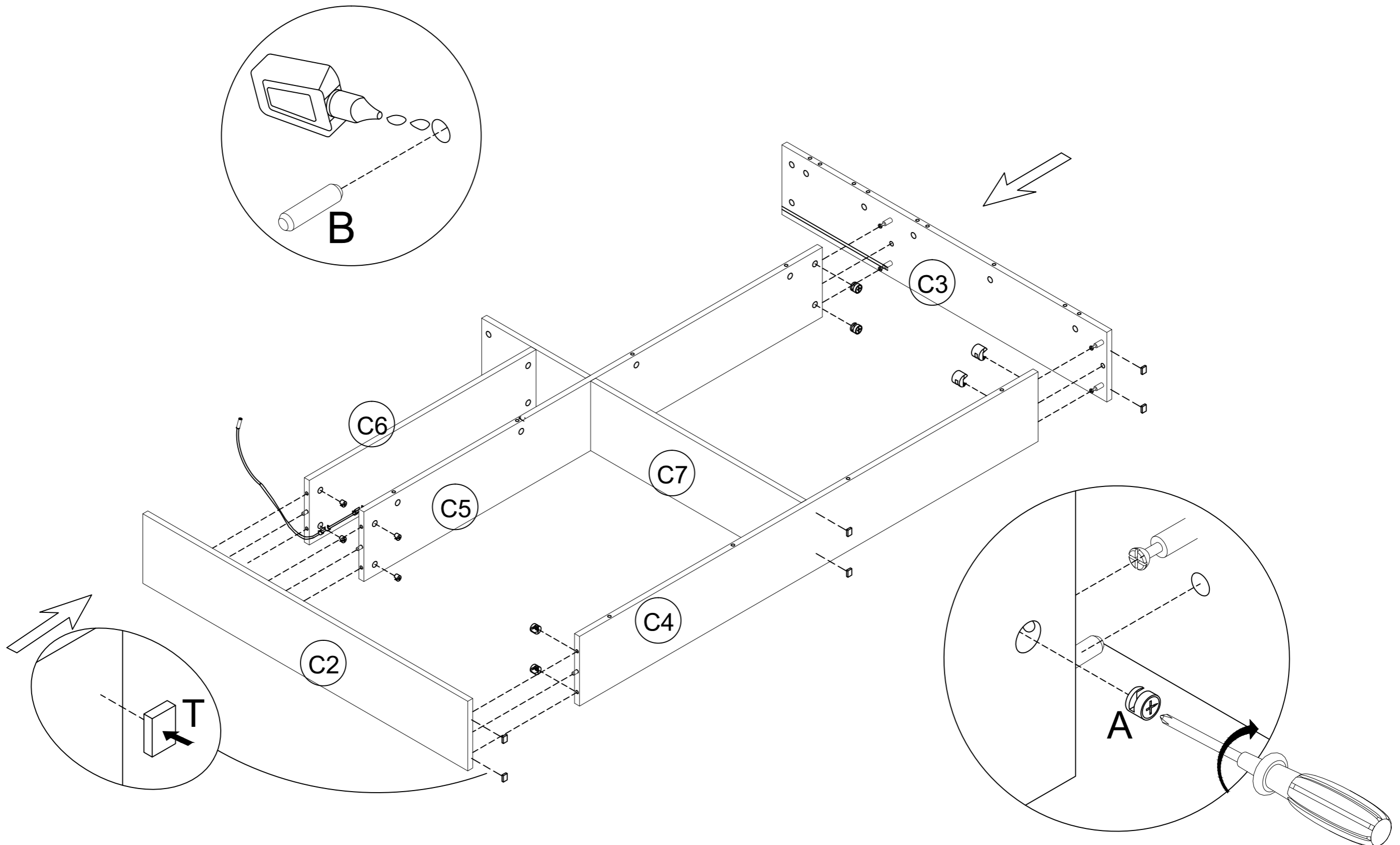

Step 10: Attach Panel(C10&C11) to Panel(C9) and attach Panel(C9&C10&C11) to Panel(C2&C3). And turn Cam Lock(A) to lock into the head of Cam Pin(A).

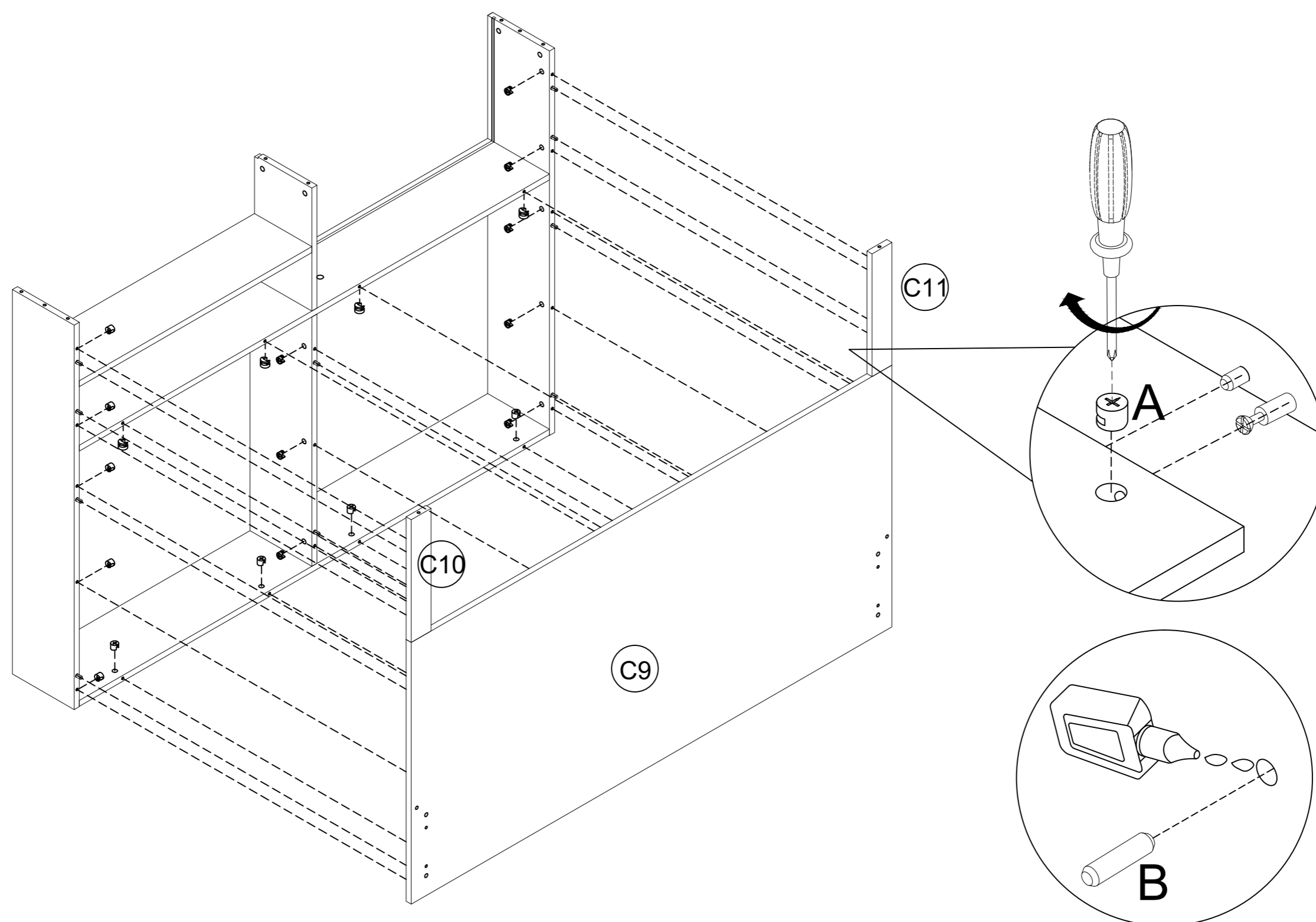

Step 11: Insert Panel(C12) to groove. Attach Panel(C1) to Panel(C2&C3&C8&C10&C11). And turn Cam Lock(A) to lock into the head of Cam Pin(A).

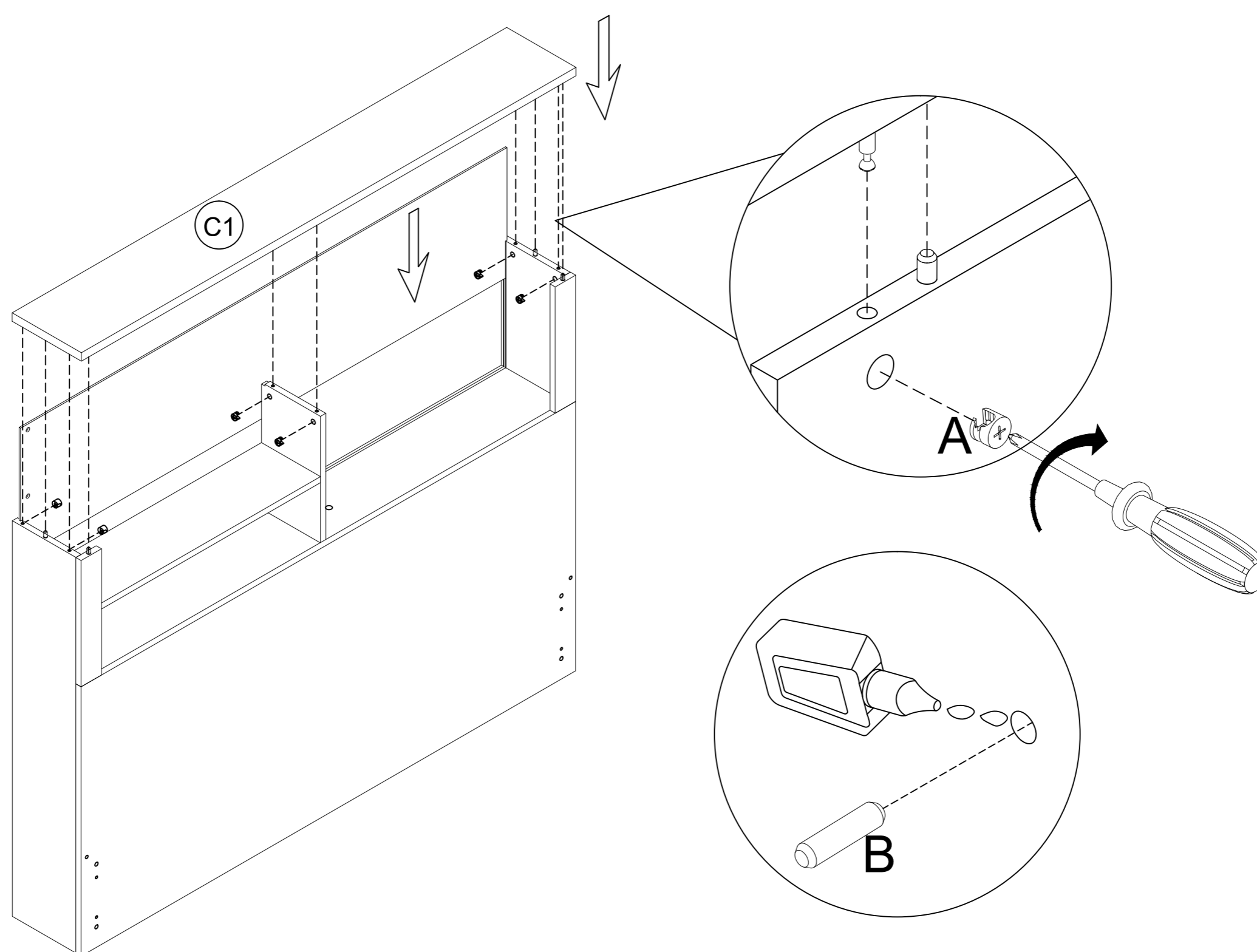

Step 12: Attach Connector(F) to Back corner with Screw(E).

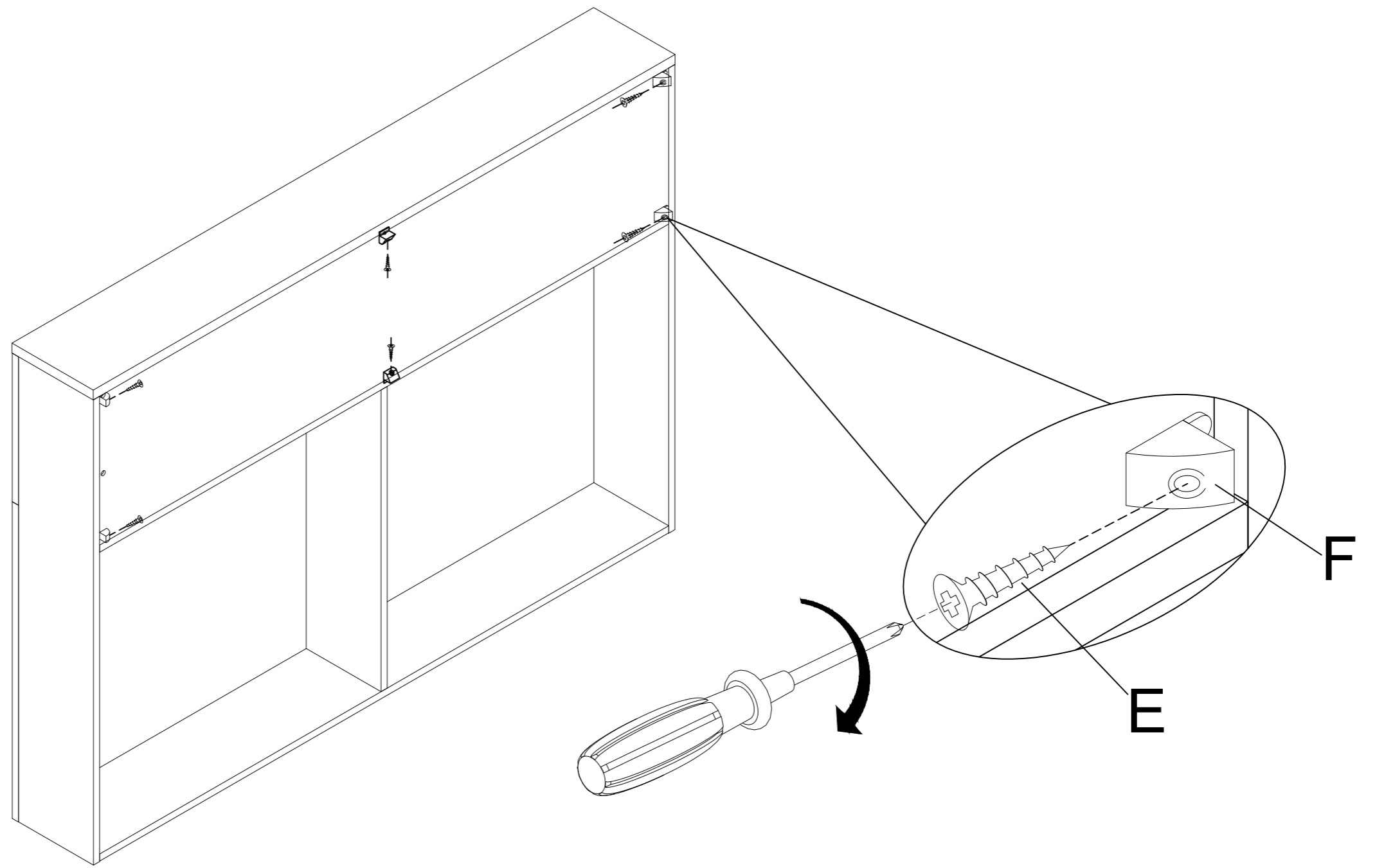

Step 13: Attach Panel(C16) to Panel(C15) with Screw(Z).

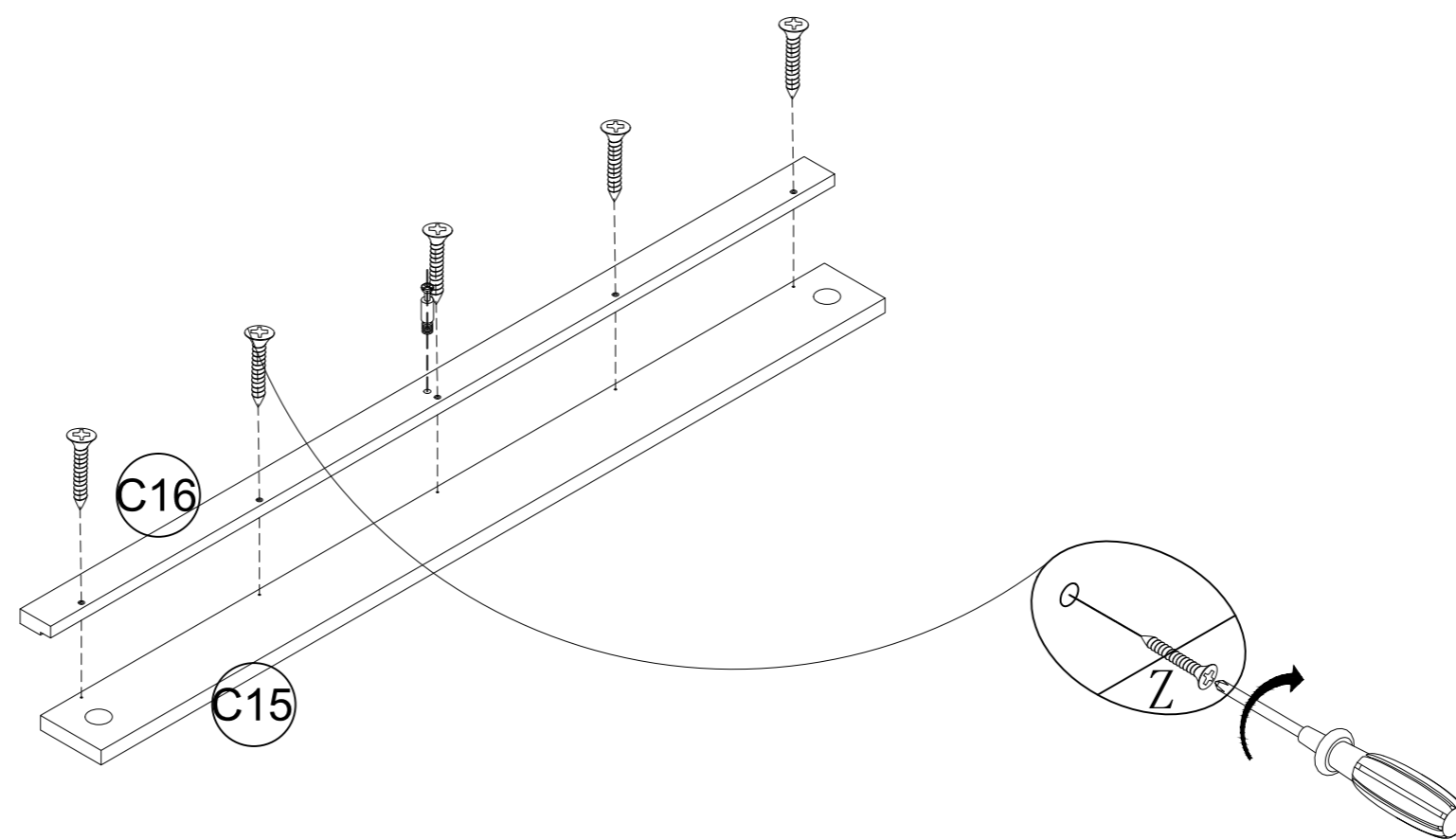

Step 14: Attach Panel(C19) to Panel(C17&C18).And turn Cam Lock(A) to lock into the head of Cam Pin(A).

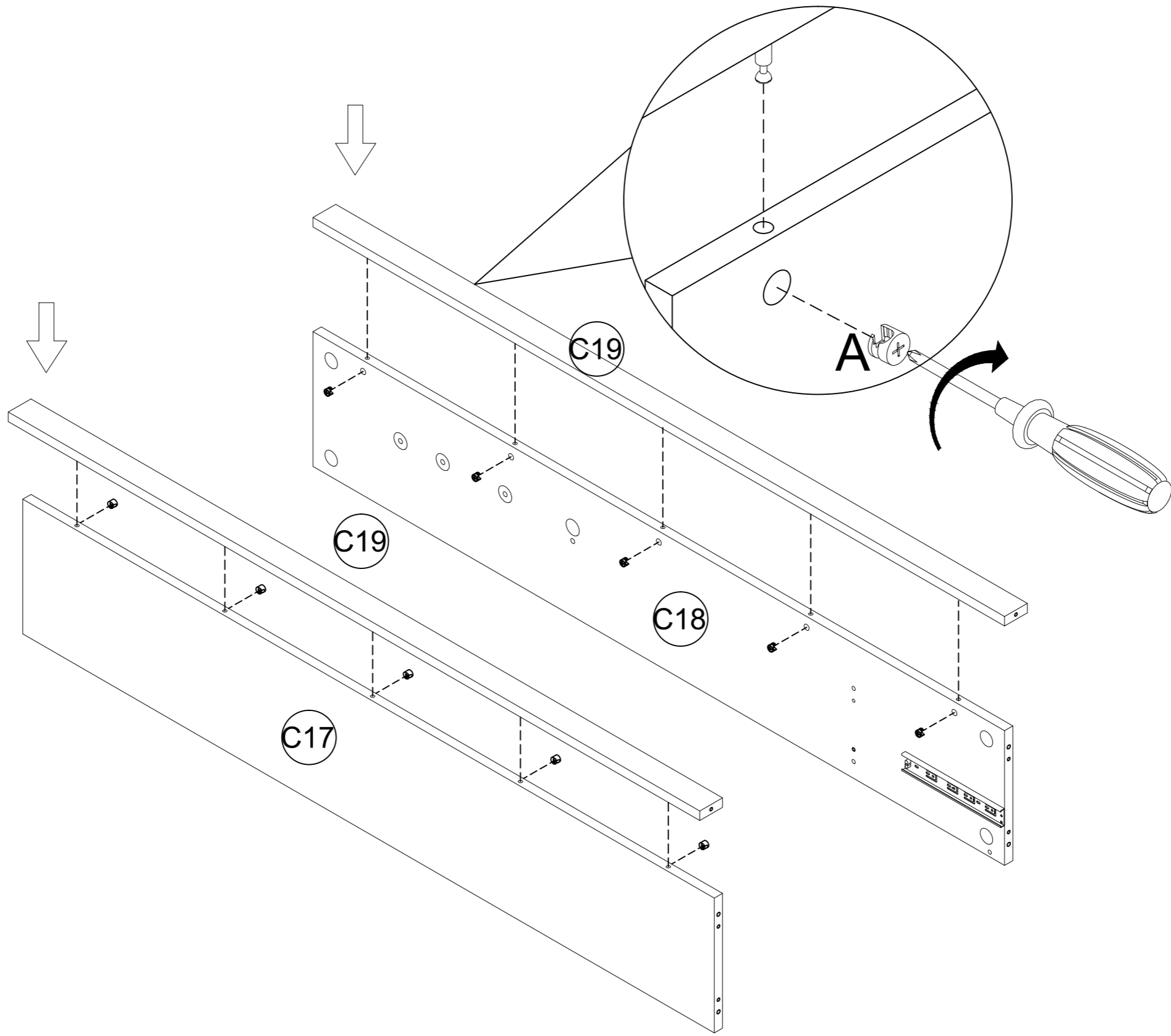

Step 15: Attach Panel(C21) to Panel(C20&C22).And turn Cam Lock(A) to lock into the head of Cam Pin(A).

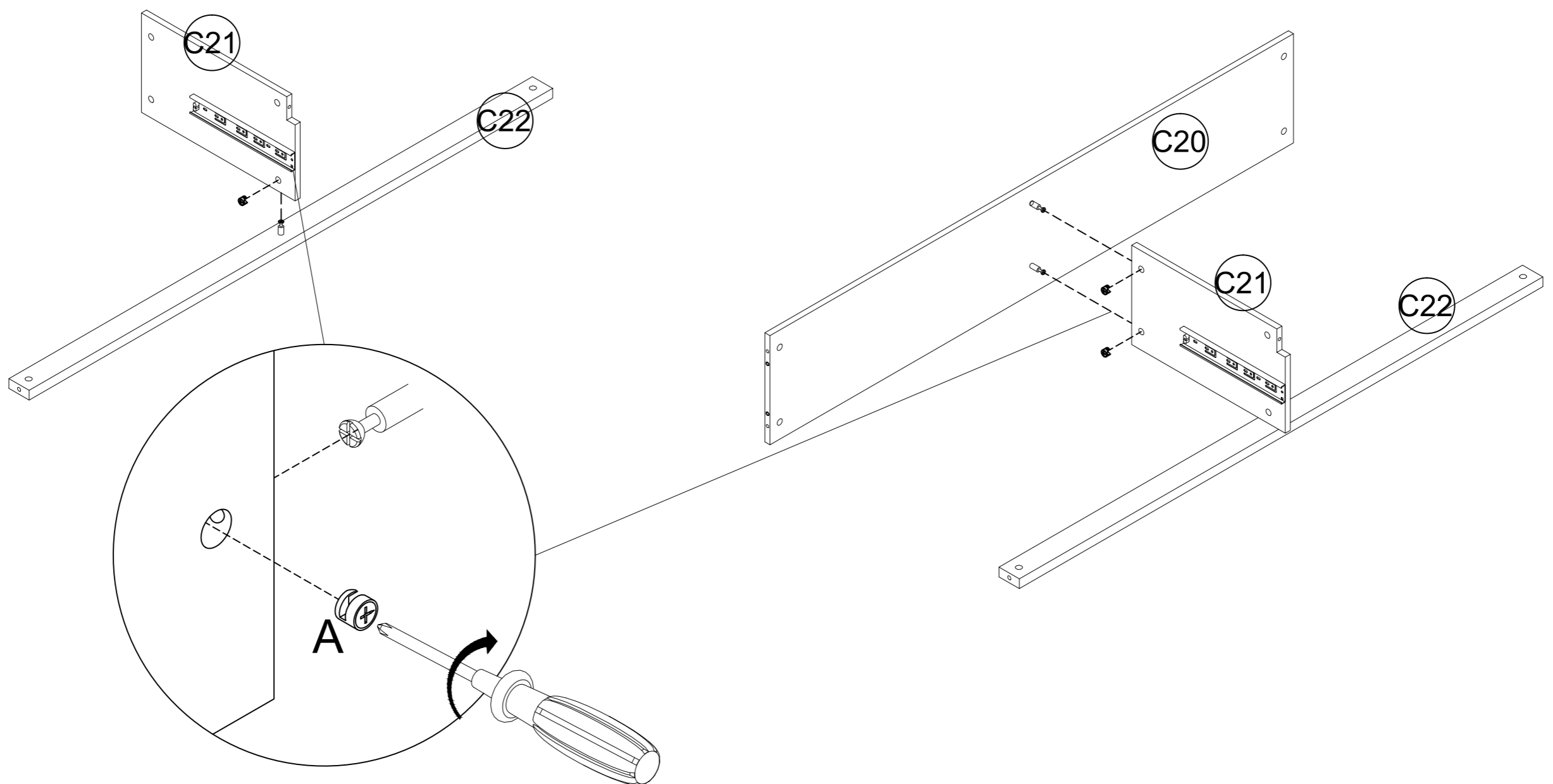

Step 16: Attach Panel(C20&C22) to Panel(C17&C18).And turn Cam Lock(A) to lock into the head of Cam Pin(A).

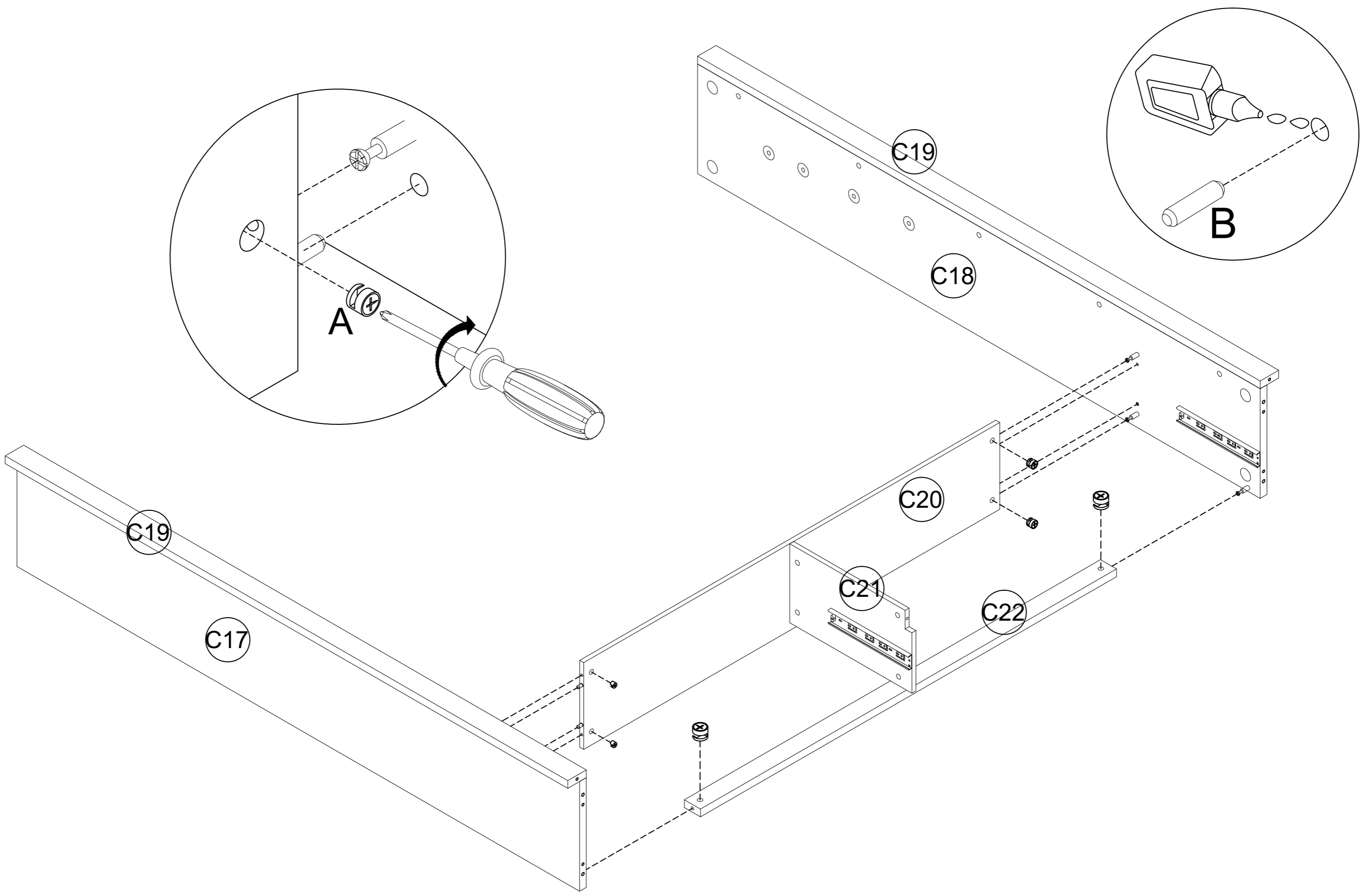

Step 17: Use Wrench(P) to attach Panel(C13&C14) to Panel(C15) with Half Round Nuts(H) and Hexagonal Nuts(I).

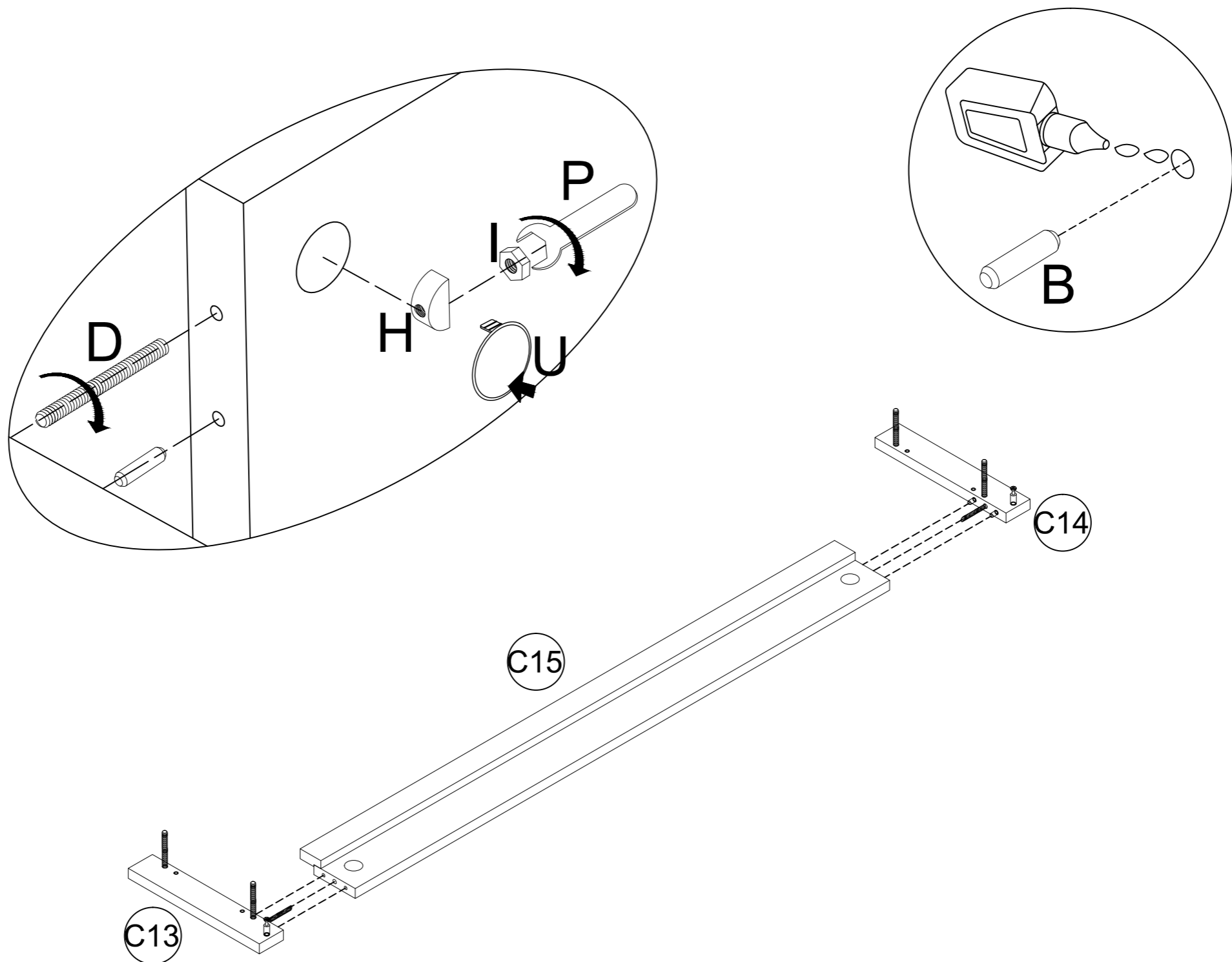

Step 18: Use Wrench(P) to attach Panel(C13&C14&C15) to Panel(C17&C18&C19) with Half Round Nuts(H) and Hexagonal Nuts(I).

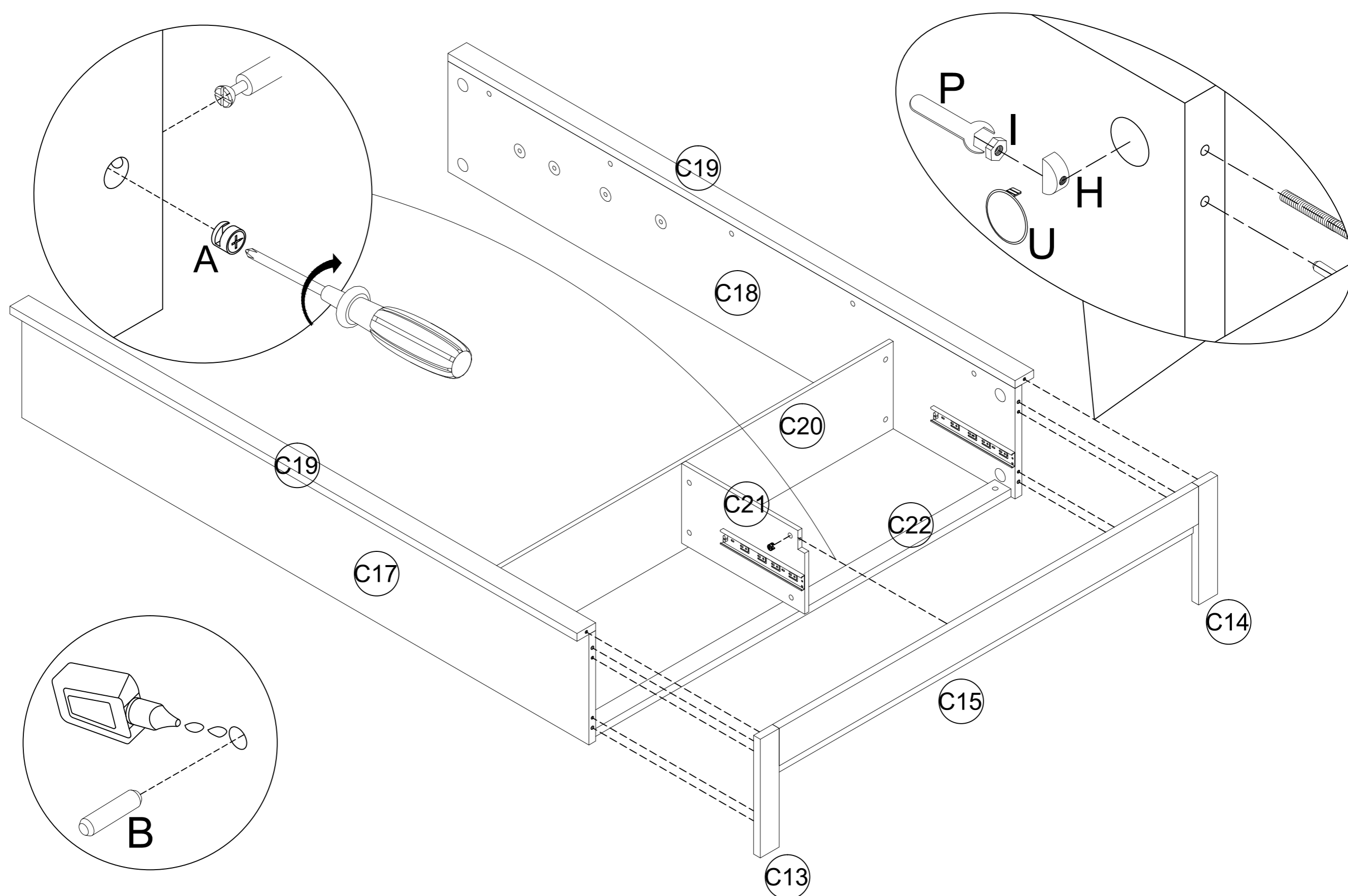

Step 19: Use Wrench(P) and Hex Key(N) to attach Panel(C17&C18&C19) to Panel(C2&C3) with Half Round Nuts(H) and Hexagonal Nuts(I) and Bolt(C). And turn Cam Lock(A) to lock into the head of Cam Pin(A).

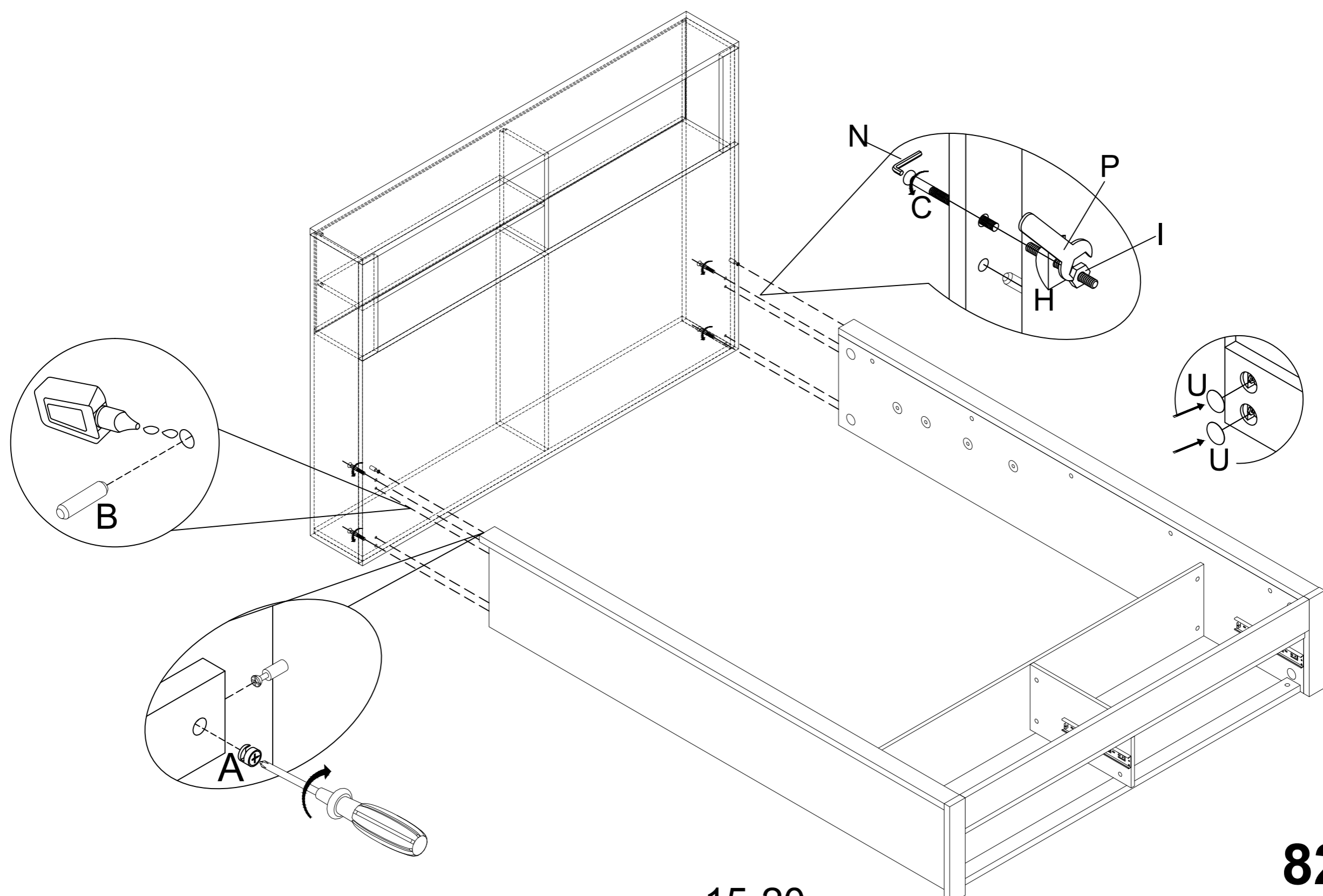

Step 20: Use Hex Key(N&O) to attach Handle(C31) and Middle Leg(C34) to Slate(C30) with Bolt(Y&K).

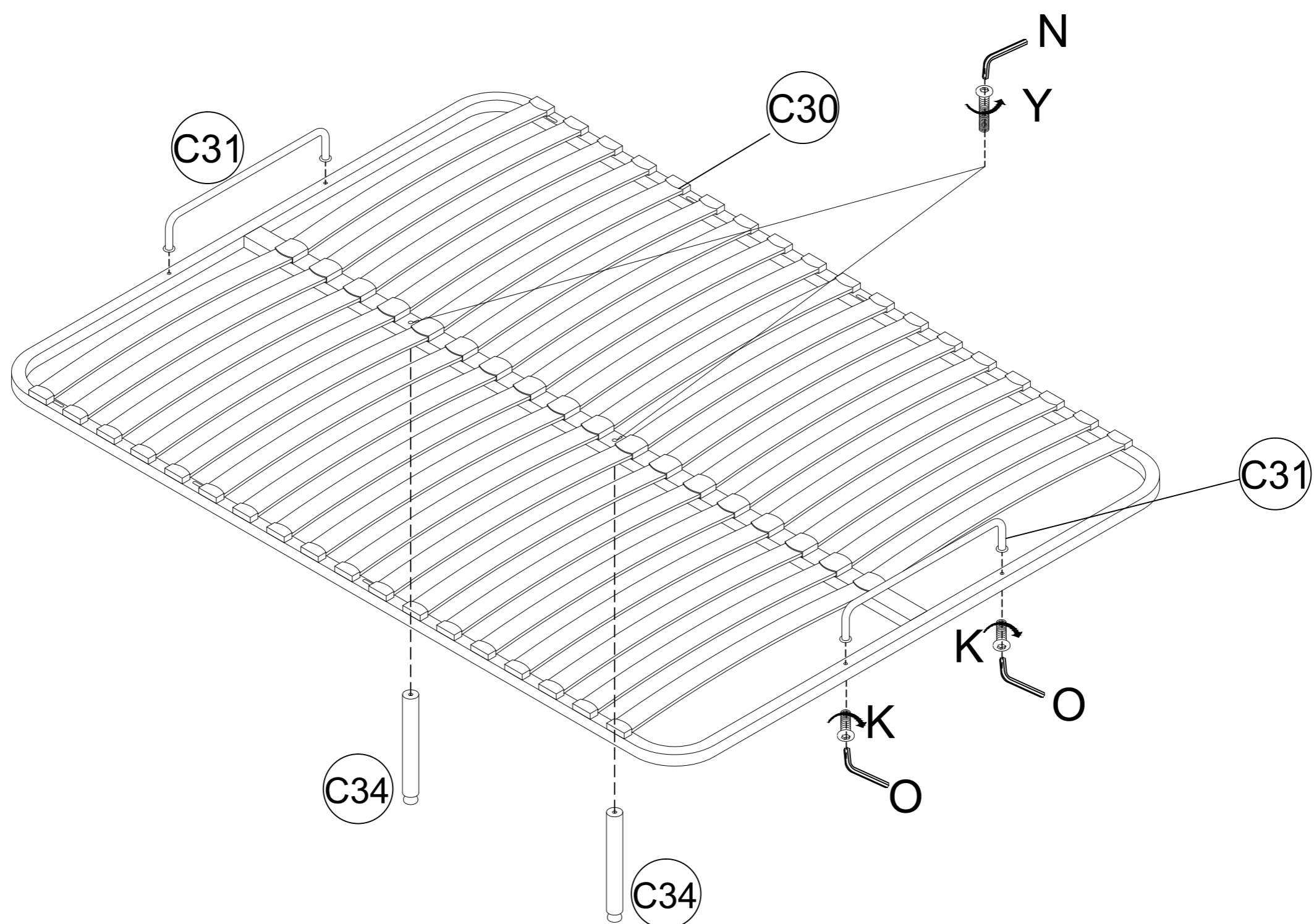

Step 21: Use Hex Key(N) to attach Gas Lift(C32&C33) to Panel(C17&C18) with Bolt(G) and Washer(S).

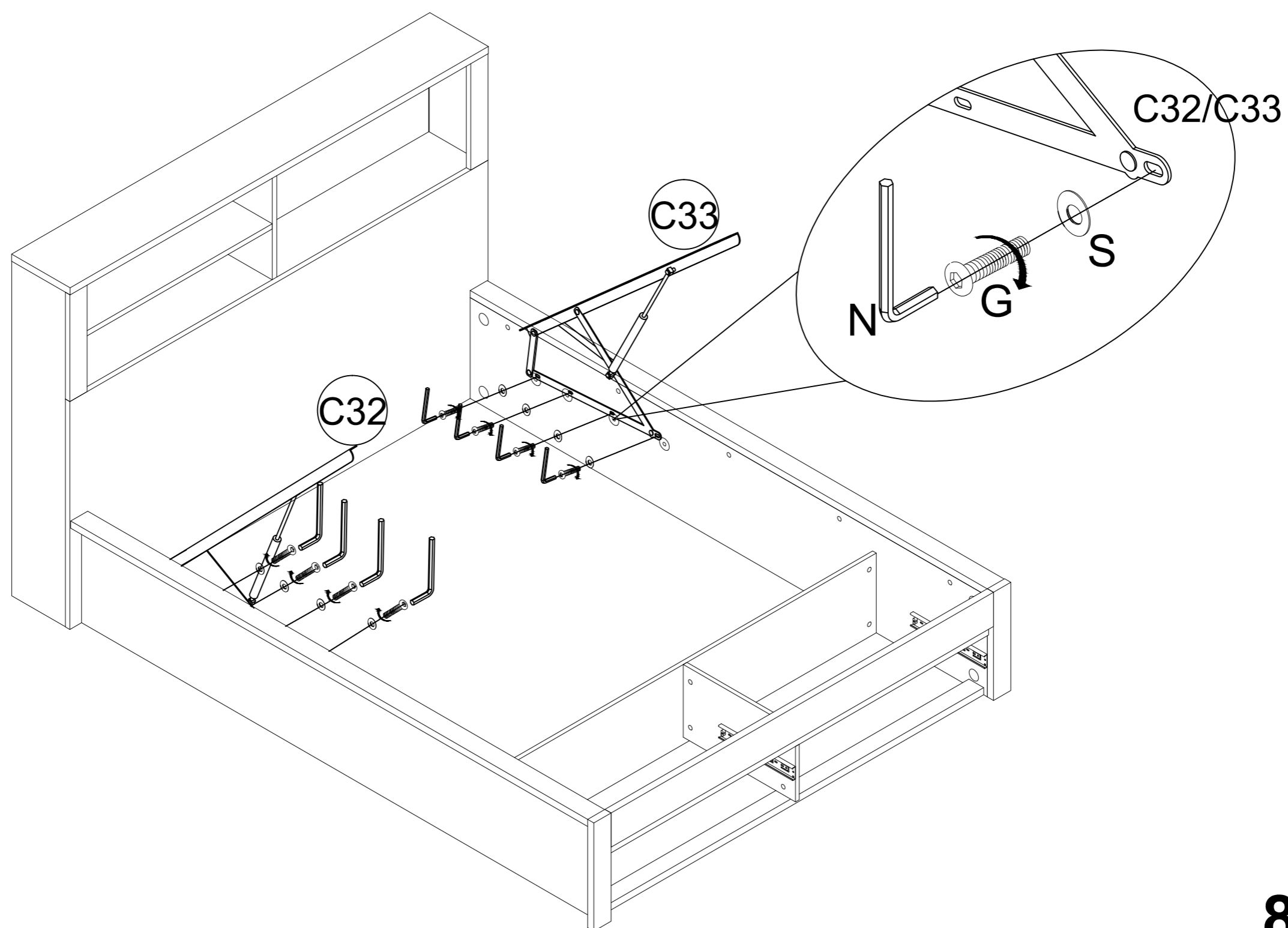

Step 22: Use Wrench(Q) and Hex Key(O) to attach Slate(C30) to Gas Lift(C32&C33) with Bolt(K) and Washer(R) and Hexagonal Nuts(J).

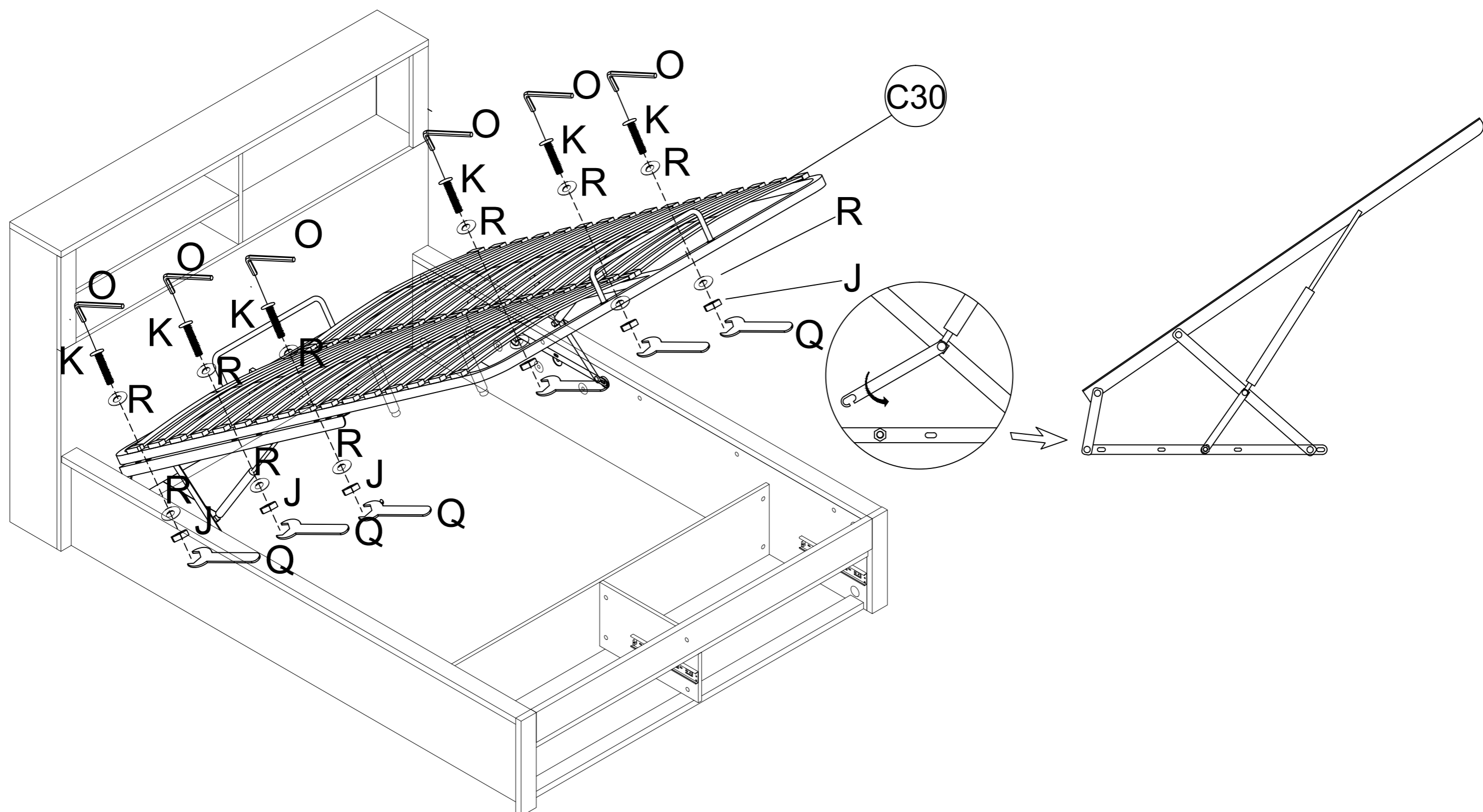

SAFETY CAUTION WARNING

Please always lock the safety lock mechanism while the bed base is in lifting position. Unlock it before you want to put the bed base back into normal position.

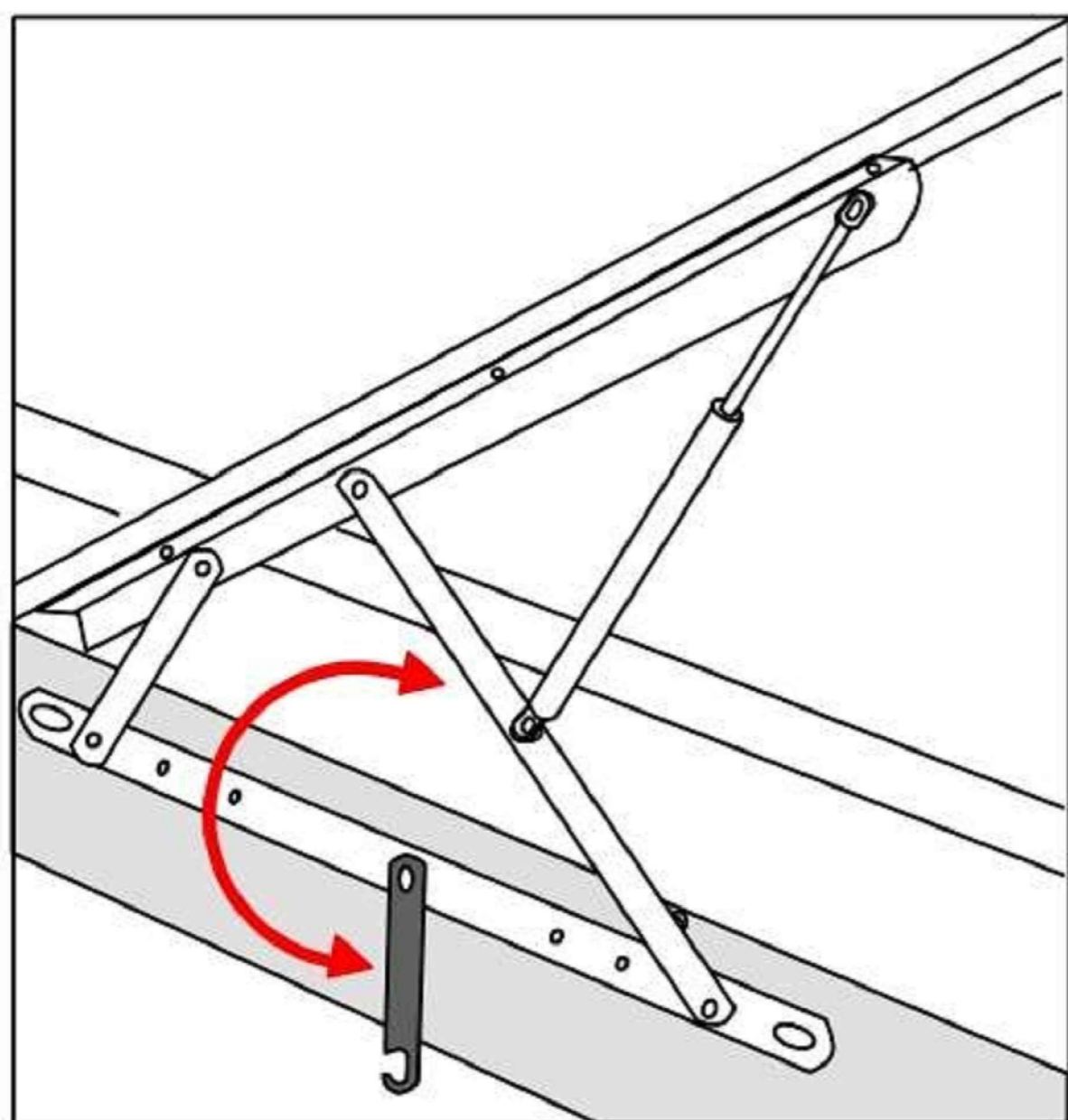

UNLOCK POSITION

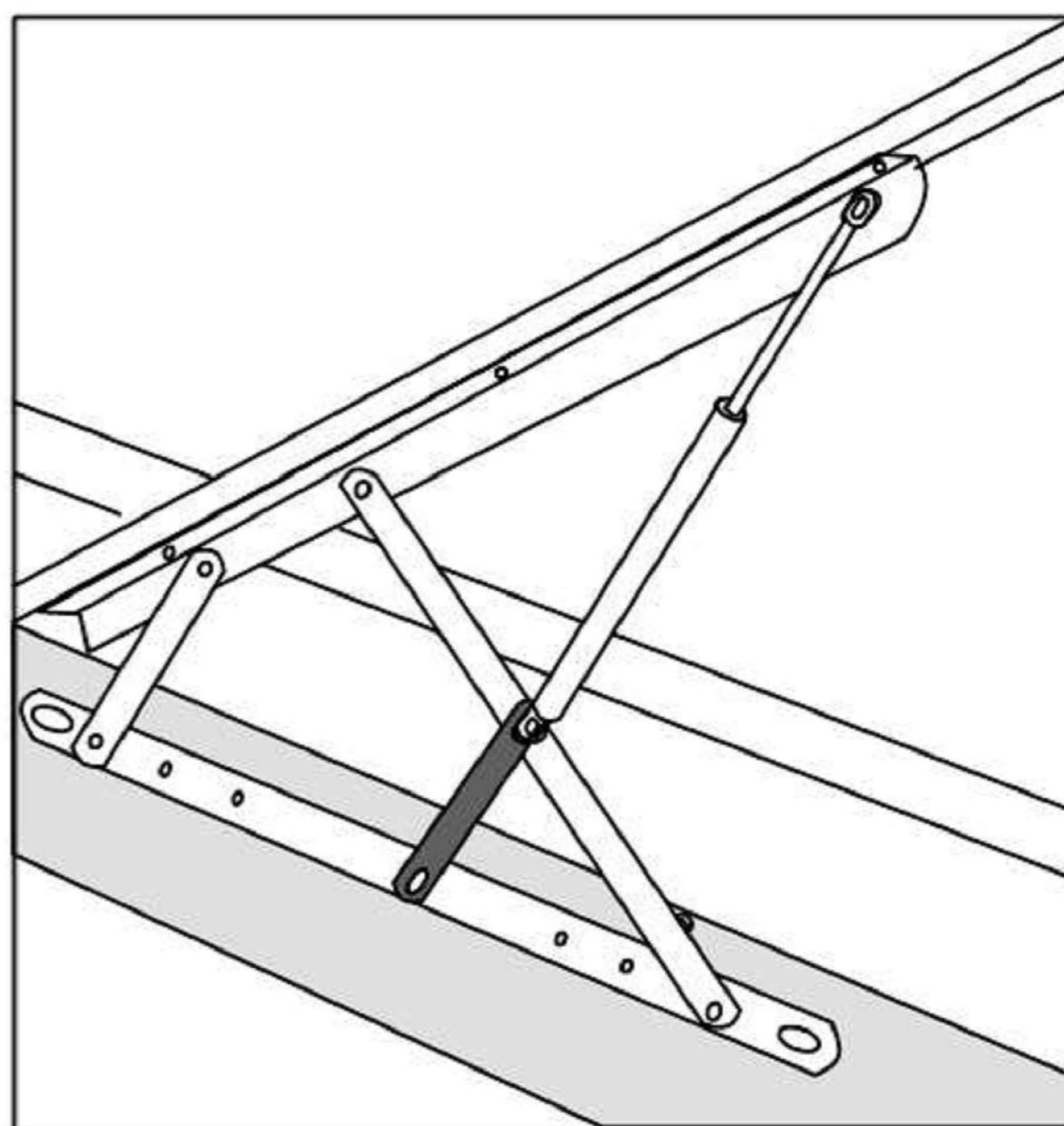

LOCK POSITION

Step 23: Attach Panel(C25&C26&C28) to Panel(C23&C24).And turn Cam Lock(A) to lock into the head of Cam Pin(A).Insert Panel(C29) to groove. And attach Panel(C27) and Runner(X) to Panel(C25&26) with Screw(M&L).

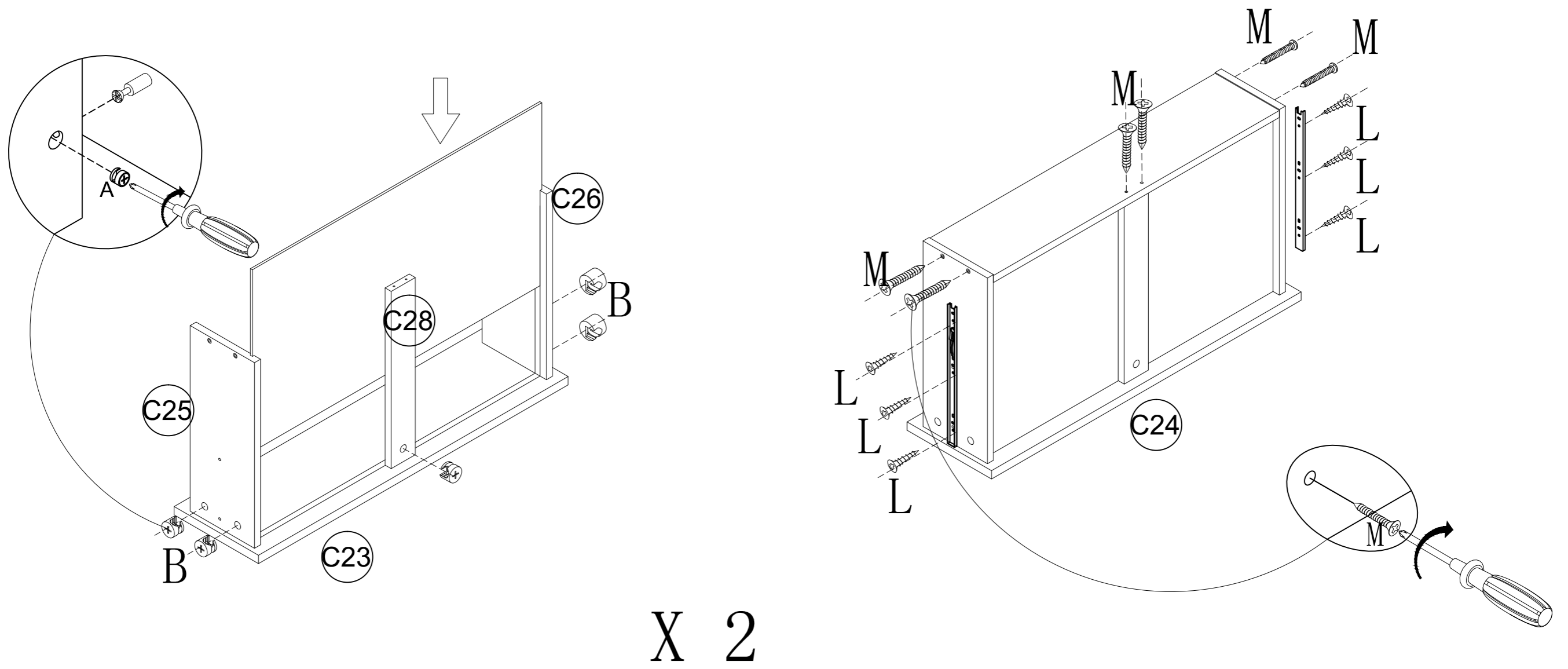

Step 24: Insert drawer into the body.

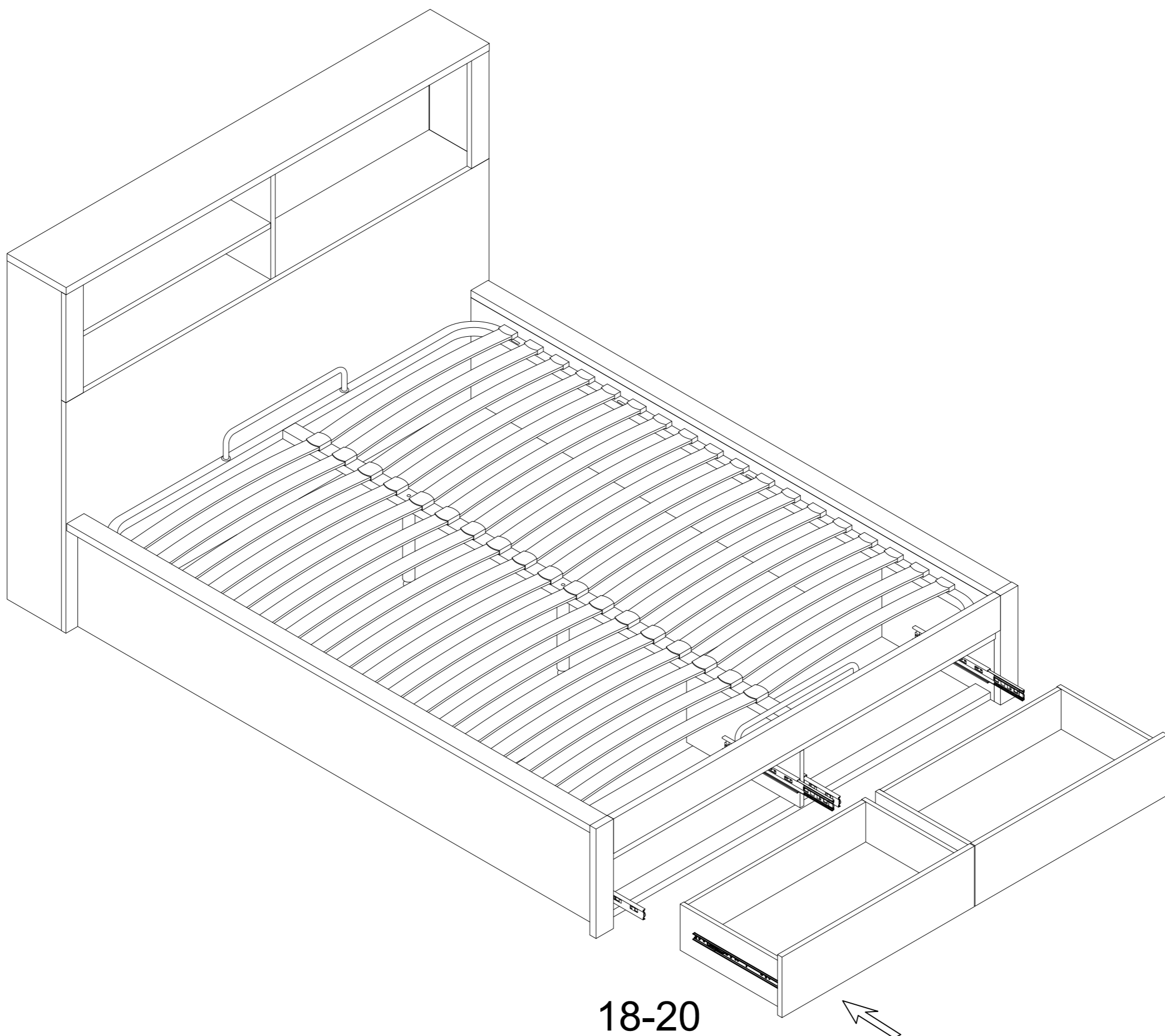

82505

Step25: Put the Sticker(W) into the Clip(W) first. And then Put the Clip(W) into Back Panel (C12).

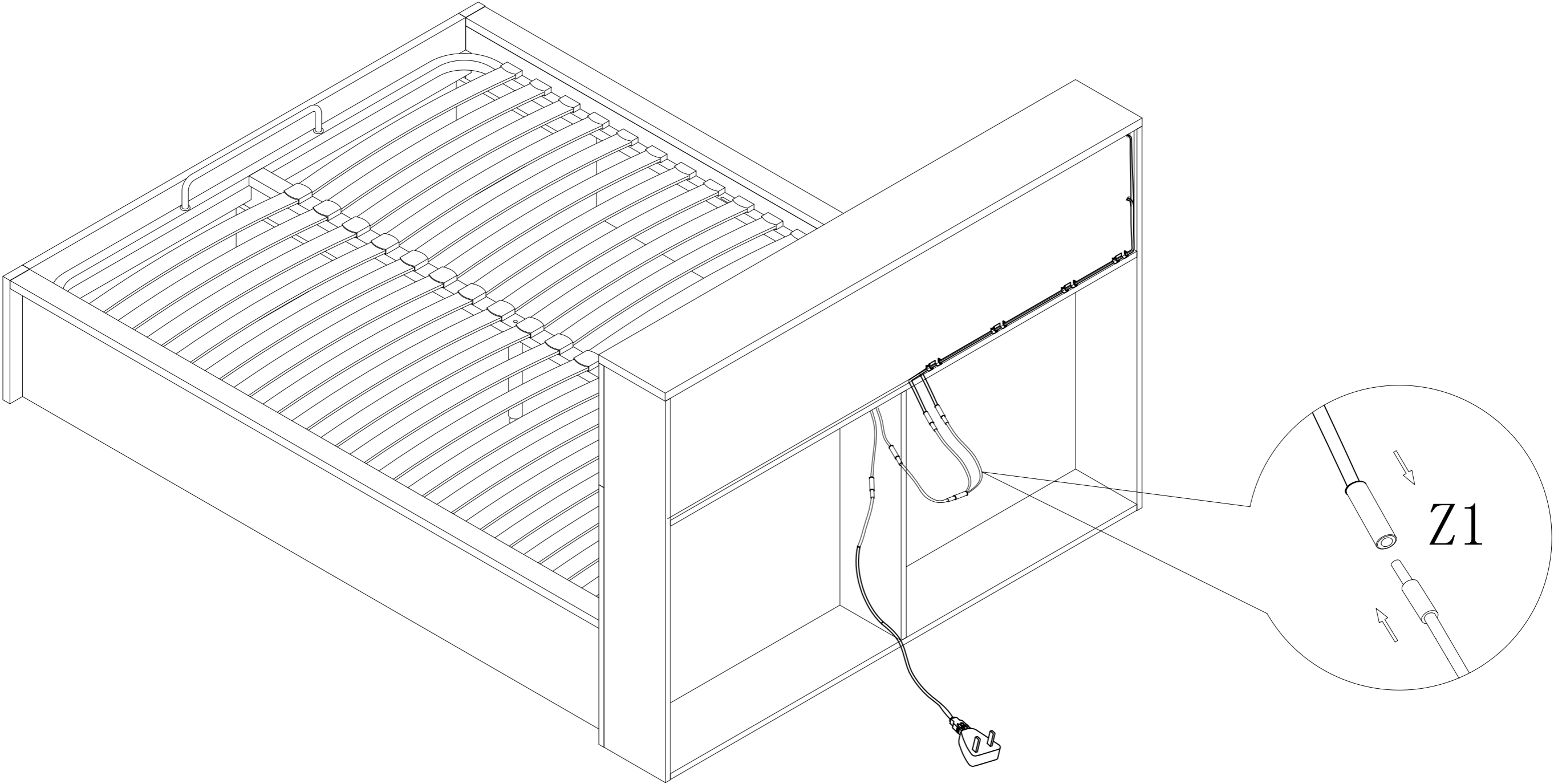

Assembly is complete

WARNING

PINCH HAZARD: BEWARE OF YOUR FINGERS WHEN LIFTING AND LOWERING THE MECHANISM

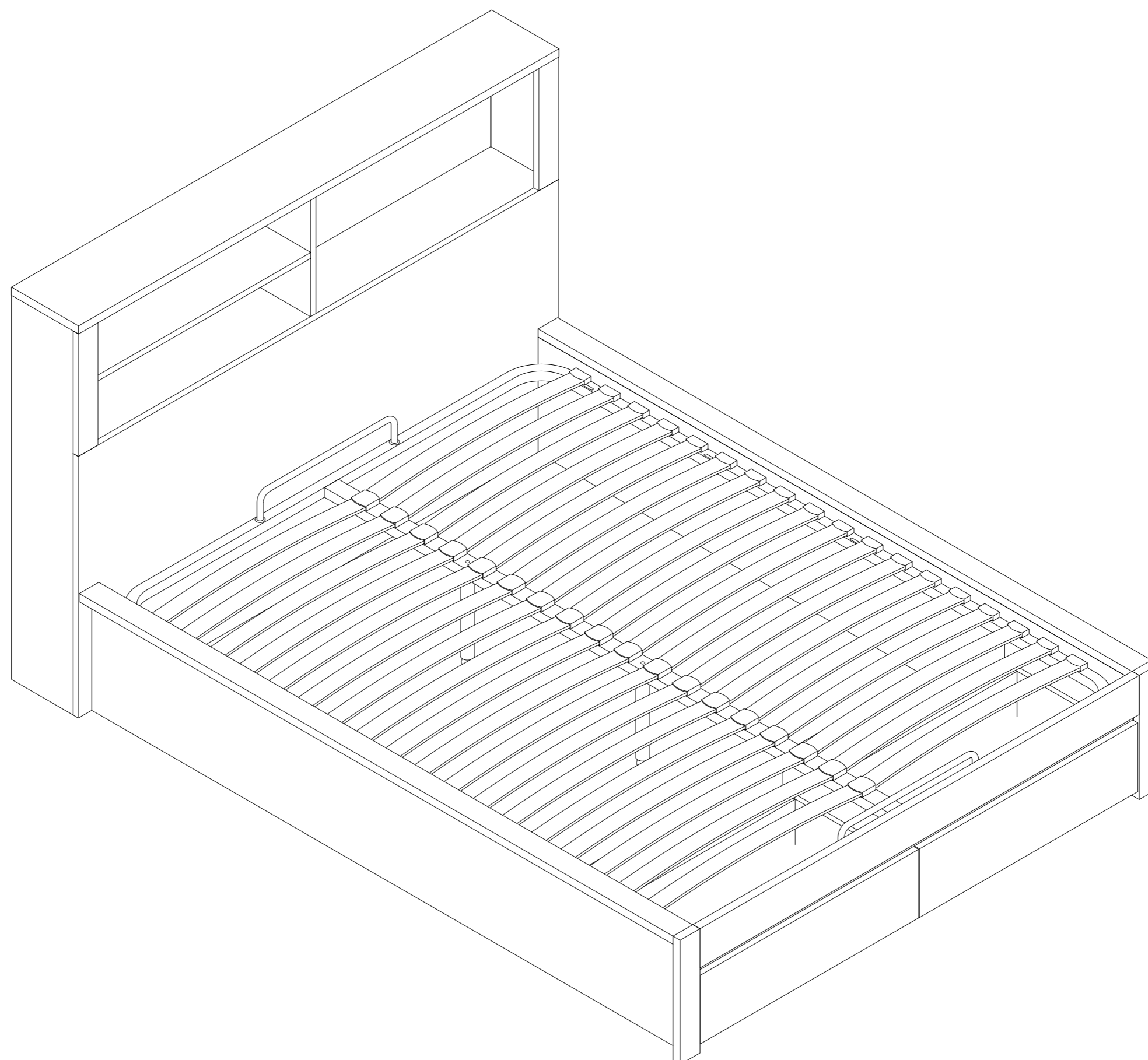

IMPORTANT NOTE:

Once the bed is positioned and the support legs are adjusted to touch floor , the slats can then be laid down and secured before putting on the mattress. DO NOT push or pull the bed if there is a need for re-positioning as this may result in broken support legs for the centre rail.

82505

PRODUCT CARE:

To protect your furniture, we suggest the following:

- Avoid placing your furniture in direct sunlight.
- Do not place furniture directly under windows.
- Do not place sharp materials (knife, fork, etc.) directly onto your furniture as sharp material may scrape and damage the finish.
- Do not place material with high temperature directly onto the surface of your furniture.
- Clean up spills quickly. Water left over a prolonged period of time may cause damage. Alcohol, perfume, nail polishes, aftershave and some medication may cause severe finish damage if not cleaned immediately.
- Use a clean, soft, dry, lint free absorbent cloth to clean your furniture. Do not use any detergent as they may contain ingredients that may react and damage the finish.
- NOTE: If the above care advise is not adhered to your product warranty may become void