



## ASSEMBLY INSTRUCTION

### SHADOW2 1635 SQUARE OUTDOOR TABLE

ITEM CODE: 51382

Imported by Amart Furniture Pty Ltd, Qld, Brisbane Australia.

For any assistance with assembly or for missing parts please phone Amart Furniture, Customer Service Free call 1800 009 466

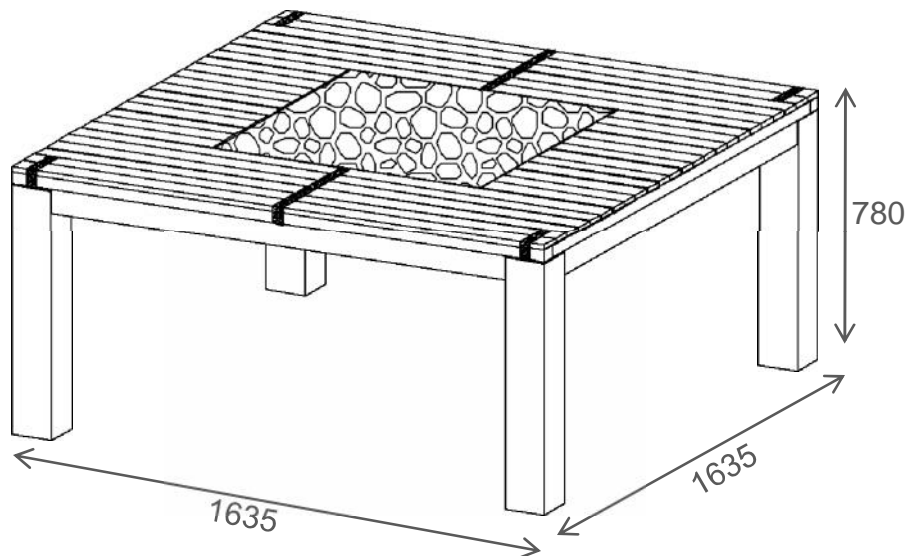



Imported by Amart Furniture Pty Ltd, Qld, Brisbane Australia.

For any assistance with assembly or for missing parts please phone Amart Furniture, Customer Service Free call 1800 009 466

## PRE-ASSEMBLY PREPARATION



### Before you start:

1. Choose a clean, level, spacious assembly area. Avoid hard surfaces that may damage the product
2. Take care when lifting. Product should be assembled as near as possible to the point of use
3. Ensure that you have all required contents for complete assembly
4. Always read the assembly instructions carefully before beginning assembly.
5. Keep all hardware parts and packaging out of reach of small children.
6. Do not over tighten the screws and bolts as this may damage the threads

	
ALLOW 15MINUTES	PEOPLE REQUIRED
ADDITIONAL TOOLS REQUIRED	

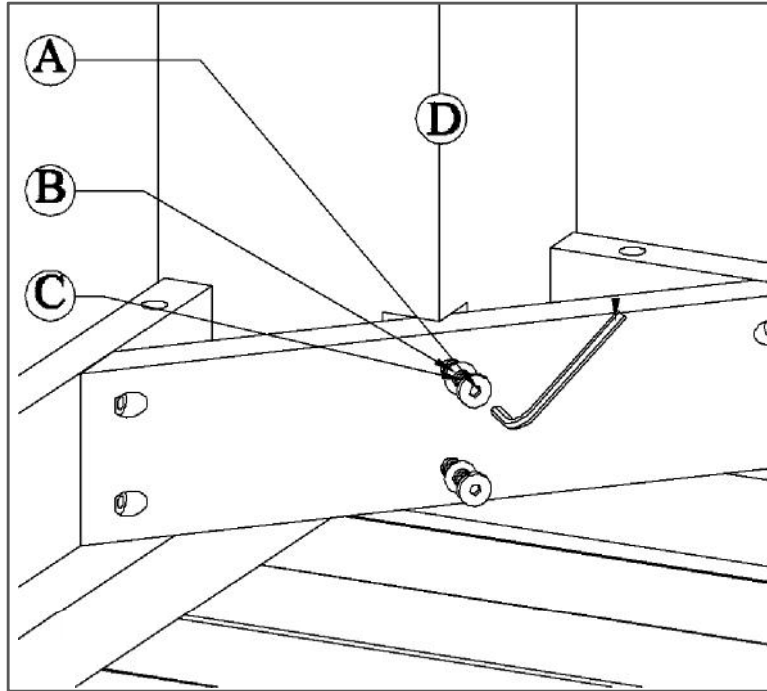
# PARTS LIST

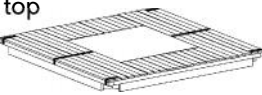

No	COMPONENT PARTS	Qty
1	Table top 	1pc
2	Granite top 	1pc
3	Legs 	4pcs

No	HARDWARE LIST		Qty
A		Bolts M8x60mm	8pcs
B		Washer Ø16x1mm	8pcs
C		Spring washer Ø12x1.5mm	8pcs
D		Allen key	1pc

**Step 1:** Carefully turn the table top upside down. Attach table top and legs as shown in diagram using bolts (A) and washers (B&C). Tighten using the allen key (D) provided.

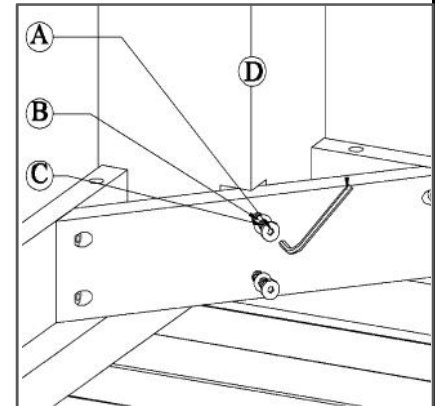
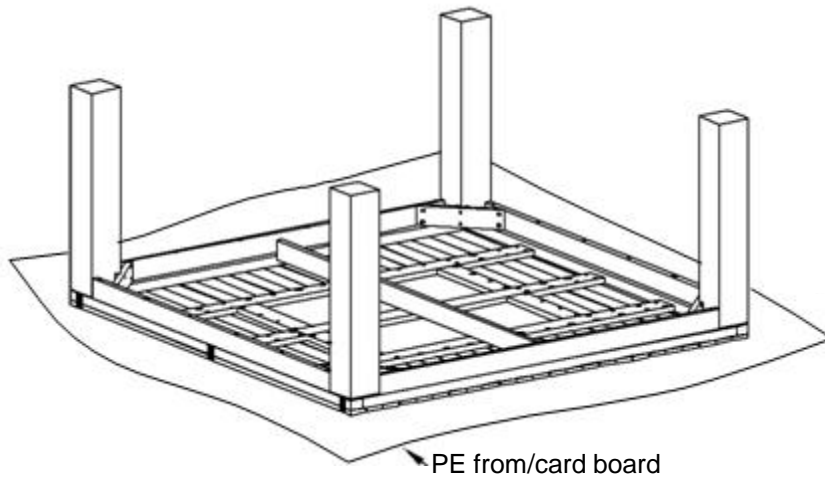

**Step 2:** Using two people carefully turn the table upright and then place the granite stone on table top as shown in diagram

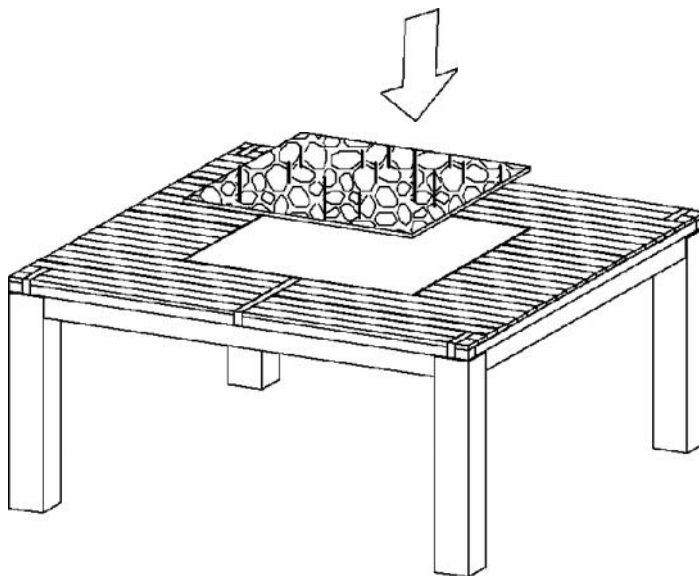

**ASSEMBLY IS COMPLETE**

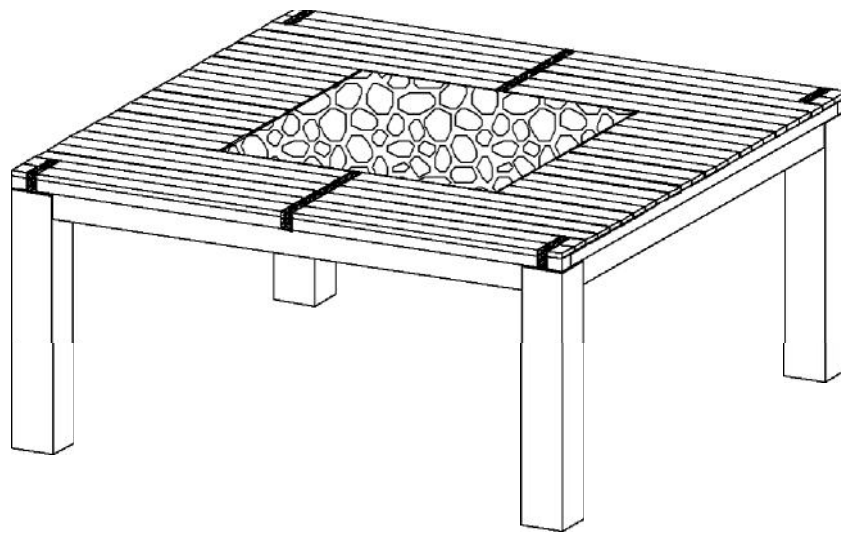

## **IMPORTANT: CARE GUIDE FOR YOUR TIMBER FURNITURE**

*Congratulations! You have just purchased a quality product from Amart furniture.*

*Please read on for important information regarding your purchase...*

A multi-step finish is applied to all our furniture, but all wood comes from nature. Because of this, there will be natural variations in surface texture and grain like knots, mineral streaks and sap runs that may affect the finish.

These differences in character are not defects, but distinctions that make each piece of furniture unique.

Our furniture is built to last. Following these steps for basic care should protect your investment for years to come.

### **TIMBERS:**

- Prolonged exposure of timber items to the elements may cause premature deterioration
- Regular vacuuming and dusting of items is recommended
- Timber requires regular maintenance and upkeep. Please use the appropriate product to maintain your product (oil/wax), if you are unsure of which product is suitable – please contact the store that you purchased from
- Minor cracking of timber is a natural process and will not compromise the strength of the timber
- To extend the life of your product the use of an Amart approved Outdoor Furniture Cover is highly recommended. Please contact store of purchase for further details

### **GRANITE:**

Do not place very hot or cold items on the granite surface unless adequately thick table mats are used to prevent such items coming in contact with the granite

Do not sit or stand upon the granite surface

Do not use the granite as a chopping surface

Do not strike the granite with hard or pointed items

When cleaning the granite panels use a damp cloth with washing up liquid or soft soap if necessary. Do not use washing powders or any other substances containing abrasives since these may scratch the granite

